

**HA20RTJ - HA20RTJ O - HA20RTJ PRO - HA61RTJ O - HA61RTJ PRO -
MONOCHROME LCD DISPLAY**

For online reference and to download the manuals for your machines HAULOTTE®, go to :
<https://www.e.technical-information.com>
or, scan the QR Code below :



Operator's manual

**HA20RTJ - HA20RTJ O -
HA20RTJ PRO - HA61RTJ O -
HA61RTJ PRO -
Monochrome LCD display**

4001196370

E 11.21

USA / GB

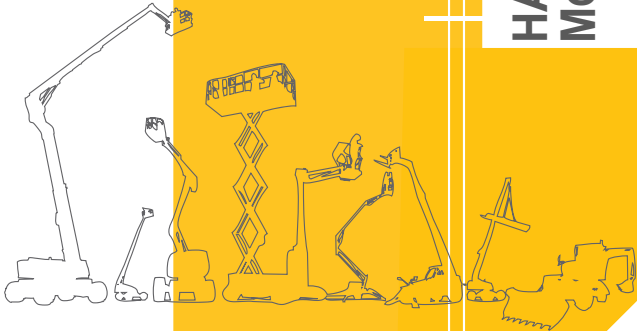

A**FOREWORD**

1 - User responsibility	8
1.1- Owner's responsibility	8
1.2- Employer's responsibility	8
1.3- Trainer's responsibility	8
1.4- Operator's responsibility	9
2 - Safety	10
2.1- Safety instructions	10
2.1.1- Incorrect use	10
2.1.2- Falling Hazards	10
2.1.3- Overturning / Tip-over Hazards	12
2.1.4- Risk of electric shock (electrocution)	14
2.1.5- Explosion / Fire Hazards	15
2.1.6- Crushing / Collision Hazards	16
2.1.7- Risk of involuntary movements	17
3 - Safety inquiries	17
4 - Incident notification	18
5 - Compliance	19
5.1- Product modification	19
5.1.1- Implementing manufacturer safety campaigns	19
5.2- Product specifications	19
5.3- Change of Ownership Notification	20
5.4- Declaration of conformity	21

B**FAMILIARIZATION**

1 - General safety	23
1.1- Intended use	23
1.2- Decal content	24
1.3- Symbols and colors	25
1.4- Level of severity	25
1.5- Symbols legend and definitions	26
2 - Models description	27
3 - Primary machine components	28
3.1- Ground control box	28
3.1.1- Layout	28
3.1.2- Display Panel (LED'S 1 - 10)	32
3.1.2.1- Fault and alarm codes	34
3.2- Platform control box	36
3.2.1- Layout	36
3.2.2- Display Panel (LED'S 101 - 117)	39
3.3- DPF (Diesel Particle Filter) (If equipped)	42
3.3.1- Automatic regeneration	48
3.3.2- Manual regeneration	48
3.3.3- To inhibit regeneration	48
3.3.4- To stop manual regeneration	48
4 - Performance Specifications	49
4.1- Technical characteristics	49
4.2- Working area / Range of motion	55
5 - Decals and markings locations	56

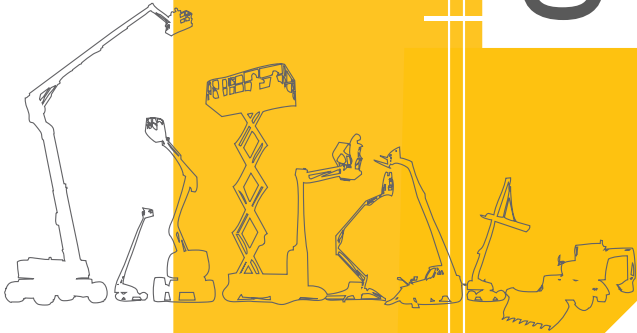
CONTENTS

C**PRE-OPERATION INSPECTION**

1 - Recommendations	67
2 - Working area assessment	67
3 - Inspection and Functional test	68
3.1- Daily inspection	68
4 - Safety functional checks	71
4.1- E-Stop button check	71
4.2- Activation of controls	72
4.3- Fault detector	72
4.3.1- Indicators/LED's test	72
4.3.2- Buzzers test	72
4.4- Automatic engine cut-out	73
4.5- Overload sensing system	73
4.6- Oscillating axles (if equipped)	73
4.7- Slope warning device	74
4.8- Travel speed limitation	75
4.9- On-board electronics	75

D**OPERATION INSTRUCTIONS**

1 - Operation	77
1.1- Introduction	77
1.2- Major description	77
1.3- Operation from the ground control box	77
1.4- Operation from the platform control box	79
2 - Ground control box	81
2.1- To start and stop the machine - Diesel engine	81
2.2- To start and stop the machine - Petrol / gas (Propane) Engine	81
2.3- Movement control	83
3 - Platform control box	85
3.1- To start and stop the machine	85
3.1.1- To start the machine	85
3.1.2- To stop the engine	85
3.1.3- If engine is stopped by Stop Emission System	85
3.2- To start and stop the machine - Petrol / gas (Propane) Engine	86
3.3- Drive and steer control	87
3.4- Movement control	88
3.5- Additional controls	89
4 - Rescue and emergency procedures	90
4.1- In case of power loss	90
4.2- To rescue operator in platform	91
4.2.1- Operation of overriding system from ground control box	91
4.3- No power available	92



5 - Transportation	93
5.1- Transport configuration	93
5.2- Machine stowage for transport - HA20RTJ - HA20RTJ O - HA20RTJ PRO - HA61RTJ O - HA61RTJ PRO	94
5.3- Unloading	95
5.4- Towing	96
5.4.1- Disengaging the drive hubs	96
5.4.2- Re-engaging the drive hubs	97
5.5- Storage	98
5.6- Lifting operation	99
6 - Cold Weather Recommendations	101
6.1- Engine oil	101
6.2- Hydraulic oil	102

E

GENERAL SPECIFICATIONS

1 - Machine dimensions	104
2 - Major component masses	106
3 - Acoustics and vibrations	107
4 - Wheel/Tire assembly	107
4.1- Technical specifications	107
4.2- Inspection and maintenance	108
5 - Options	110
5.1- On-board generator	110
5.1.1- Description	110
5.1.2- Characteristics	110
5.1.3- Safety precautions	110
5.1.4- Pre-operation inspection	110
5.1.5- Operation	111
5.2- Glazier's kit	112
5.2.1- Description	112
5.2.2- Characteristics	112
5.2.3- Safety precautions	112
5.2.4- Pre-operation inspection	112
5.2.5- Operation	113
5.2.6- Assembly / Dis-assembly	114
5.2.7- Specific decals	115
5.3- Plumber's kit	116
5.3.1- Description	116
5.3.2- Characteristics	116
5.3.3- Safety precautions	116
5.3.4- Pre-operation inspection	116
5.3.5- Operation	117
5.3.6- Assembly - Dis-assembly	118
5.3.7- Specific decals, optional	119
5.4- Activ' Shield Bar - SECONDARY GUARDING SYSTEM (If fitted) 120	
5.4.1- Description	120
5.4.2- Characteristics	120
5.4.3- Safety precautions	121
5.4.4- Pre-operation inspection	122
5.4.5- Operation	122
5.4.6- Specific decals	123
5.5- Swing gate	124
5.5.1- Description	124
5.5.2- Characteristics	124
5.5.3- Safety precautions	124
5.5.4- Pre-operation instructions	124

CONTENTS



F**MAINTENANCE**

1 - General	125
2 - Maintenance Schedule	126
3 - Inspection program	127
3.1- General program	127
3.2- Daily inspection	128
3.3- Periodic inspection	128
3.4- Reinforced inspection	128
3.5- Major inspection	129
4 - Repairs and adjustments	130

G**OTHER INFORMATION**

1 - Conditions of warranty	131
2 - Subsidiary contact information	131
2.1- California warning	132

H**INTERVENTION REGISTER**

1 - Intervention register	135
--	------------



A - Foreword

You have just purchased a HAULOTTE® product and we would like to thank you for your business.

The aerial work platform is a device for lifting people designed and manufactured with the intent to enable users to access overhead elevated temporary workplaces with the necessary tools and equipment. All other uses or alterations/modifications to the aerial work platform must be approved by HAULOTTE®.

This manual shall be considered a permanent component of the machine and shall be kept with the aerial work platform in the designated Manual Holder, at all times.

Safe operation of this product can only be assured if you follow the operating instructions contained in this manual. To ensure the safe and appropriate use of this equipment, only trained personnel are authorised to use and carry out maintenance on the aerial work platform.

We would particularly like to draw your attention to 2 essential points :

- Comply with safety instructions.
- use this equipment within the performance limits specified by this user manual.

With regard to the designation of our equipment, we stress that this is purely for commercial purposes and not to be confused with the technical specifications. Only the specifications in this manual should be used to study the suitability of the equipment for the intended use.

This operator's manual is specific to the HAULOTTE® products listed on the cover page of this manual.



Original language and version :

Manuals in English and French are the original instructions. Manuals in other languages are translations of the original instructions.

The user manual does not replace the necessary training that is required for all of this machine's operators. HAULOTTE® has compiled this manual to assist in safe and efficient operation of the products covered in the manual. The manual must be available to all operators and must be kept in a legible condition. Additional copies can be ordered from HAULOTTE Services®.

Stay Safe and keep working with HAULOTTE® !

For online reference and to download the manuals for your machines HAULOTTE®, go to :

<https://www.e.technical-information.com>

or, scan the QR Code below :



A - Foreword

1 - User responsibility

1.1 - OWNER'S RESPONSIBILITY

The owner (or hirer) has the obligation to :

- To inform operators of the instructions contained in the Operator's Manual.
- Follow local regulations regarding operation of the machine.
- Replace all manuals or labels that are missing or in poor condition. Additional copies can be ordered from HAULOTTE Services®.
- To establish a preventive maintenance program in accordance with the manufacturer's recommendations, taking into account the environment and severity of use of the machine.
- To perform periodic inspections in accordance with HAULOTTE® recommendations and local regulations.

All malfunctions and problems identified during the inspection shall be corrected before the aerial work platform is returned to service.

1.2 - EMPLOYER'S RESPONSIBILITY

The employer (or plant superintendent) is required :

- To train and check the training of users.
- To authorise the trained user(s) to use the machine.
- To inform and familiarize the operator with the local regulations.
- Forbid anyone from operating the machine if :
 - Under the influence of drugs, alcohol, etc.
 - Subject to fits, convulsions, dizziness, etc.

1.3 - TRAINER'S RESPONSIBILITY

- The trainer must be qualified to provide training to operators in accordance with applicable local regulations.
- The training must include all of the instructions in this manual.
- The training must be given in an obstacle-free area until the trainee is considered competent as defined by the training program undertaken.

A - Foreword

1.4 - OPERATOR'S RESPONSIBILITY

The operator has the obligation to :

- Read and understand the contents of this manual and familiarize himself/herself with the decals affixed on the machine.
- To inspect the machine before use according to HAULOTTE®'s recommendations..
- Inform the owner (or hirer) if the manual or any decals are missing or are not legible.
- Inform the owner (or hirer) of any machine malfunction.

Operators must ensure that the inspections have been carried out by the owner and that they can use the machine for the purpose intended by the manufacturer.



All users (driver, passenger, maintainer, transporter, etc.) must familiarise themselves with the emergency controls and machine operation in case of an emergency.

The operator has the obligation to stop using the machine in the event of malfunction or safety problems on the machine or in the work area and report the problem immediately to his/her supervisor.

A

B

C

D

E

F

G

H

I

A - Foreword

2 - Safety

2.1 - SAFETY INSTRUCTIONS

2.1.1 - Incorrect use

- Do not use the machine outside of the conditions specified in this manual.
 - Do not use the machine as a crane, material lift or elevator.
- 
- Do not use the work platform as a hoisting machine (crane) by suspending a load outside of the platform.
 - Do not tie the boom or platform to an adjacent fixed or mobile structure.
 - Do not use/operate the machine when alone. A survey person or immediate Supervisor must be present on the ground in case of emergency.
 - Do not use a faulty or poorly maintained machine. Remove defective/damaged machine from service.
 - Do not climb onto the compartment covers of the machine.
 - Do not replace items critical to machine stability with items of different weight or specification.
 - Do not replace the wheels installed in the factory with wheels with different characteristics
 - Do not alter or disable machine components that in any way affect safety and stability.
 - Do not disable the safety devices.
 - Do not use the machine if a label is missing or illegible.
 - Do not damage, modify or hide machine labels or inscriptions.

2.1.2 - Falling Hazards

N.B.-:-THE GUARDRAIL IS THE MAIN PROTECTION SYSTEM AGAINST FALLS FROM THE MOBILE LIFTING PLATFORM (PEMP).

Before commencing operation :

- Ensure that guard rails are correctly installed and secured.
 - Ensure that gate or sliding bar is in its securely locked position.
 - If using a machine that has a swing gate, check that the entry gate closes by itself and gate latches and locks.
- 
- Remove oil or grease from the steps, floor, handrail and the guardrails.
 - Clean the floor of the platform (no debris).

A- Foreword

To enter or exit from the platform :

- The machine must be completely stowed (Access configuration).
- Face the machine to access the opening to the platform.
- Keep 3 points of contact (both hands and a foot) on the steps and the guardrail.
- Keep fingers away from moving parts near entry gate.



When in the platform :

- Where personal fall protection equipment (FPE) is required by the employer, a competent authority or local regulations, we recommend using a full harness with a safety line.
- Personal fall protection equipment must only be fastened to approved fall protection anchoring points on the platform provided for this purpose.
- Refer to this decal located on the platform.
- Safety lines must never be attached to an object or structure outside of the work platform.
- Hold on securely to the guardrails.
- Always keep your feet firmly on the floor of the platform.
- Do not sit, stand, or climb on the platform guard rails.
- Do not lean on the gate or sliding bar.
- Do not lean over the guard rails or climb over them. Only work in the platform area within the guard rails.
- Do not exit the platform until it is in the completely stowed position.
- Do not use the guardrail as a means of access to climb in or out of the platform.

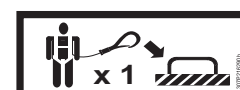

A- Foreword

2.1.3 - Overturning / Tip-over Hazards

Before positioning and operating the machine :

- Ensure that the surface is capable of supporting the machine weight including the rated capacity. Check the load bearing capacity of the supporting ground.
- Remain vigilant of driving direction reversal at the platform. Check the driving direction with the help of the red or green arrow on the chassis relative to the red and green arrows on the platform control box.
- Do not exceed the maximum rated capacity that includes the weight of both material and allowed number of occupants. Do not exceed the allowable number of occupants.
- Do not increase the working height (using extensions, ladder, etc.).
- Do not place ladders or scaffolds in the platform or against any part of this machine.
- Position loads uniformly in the centre of the work platform.
- Do not use the machine at wind speeds that are above the permissible threshold. Refer to the display on the work platform to view the permissible wind speed.
- Do not increase the surface area of the platform exposed to wind. This includes adding panels, mesh, banners. Failure to follow this instruction may lead to a loss of stability and as a result, the machine could tip over.
- Do not raise the platform or move the machine with the platform raised on a slope with a gradient greater than the machine's permissible limit.
- Do not drive the machine on slopes or grades exceeding the specified limits.
- Do not replace components critical to stability with components of different weight or specification.
- Do not use the machine with material or objects hanging from the guardrail or the boom.
- Do not pull or push towards any object outside of the platform. Do not exceed the maximum allowable side force stated in the performance specifications.
- Do not use the machine to support any external structure.
- Do not use the machine to tow other machines or to drag materials.



A - Foreword

Using the machine on a slope



Do not drive the machine on slopes with gradients exceeding the authorised transversal and lateral limits for the machine  Section B 4.1 - Technical specifications.

WIND: the aerial work platform can be used up to the maximum wind speed indicated in the specifications in this manual. To identify the local wind speed, use the Beaufort scale below, a wind gauge or an anemometer.

N.B.-:-THE BEAUFORT SCALE OF WIND FORCE IS ACCEPTED INTERNATIONALLY AND IS USED WHEN COMMUNICATING WEATHER CONDITIONS. A WIND SPEED RANGE AT 10 M (32 FT 9 IN) ABOVE FLAT, CLEAR LAND IS ASSOCIATED WITH EACH DEGREE.

Beaufort scale

Force	Meteorological description	Observed effects	m/s	km/h	mph
0	Calm	Smoke rises vertically.	0 - 0,2	0 - 1	0 - 0,62
1	Very light breeze	Smoke indicates the wind direction.	0,3 - 1,5	1 - 5	0,62 - 3,11
2	Light breeze	Wind felt on the face. Leaves rustle. Weather vanes turn.	1,6 - 3,3	6 - 11	3,72 - 6,84
3	Slight breeze	Leaves and small twigs in constant motion. Flags move slightly.	3,4 - 5,4	12 - 19	7,46 - 11,8
4	Nice breeze	Raised dust and loose papers. Small branches are moved.	5,5 - 7,9	20 - 28	12,43 - 17,4
5	Nice breeze	Small trees in leaf to sway. Crested wavelets form on inland waterways.	8,0 - 10,7	29 - 38	18,02 - 23,6
6	Cool wind	Large branches in motion. Power lines and chimneys 'sing'. Umbrellas used with difficulty.	10,8 - 13,8	39 - 49	24,23 - 30,45
7	Near gale	Whole trees in motion. Inconvenience felt when walking against wind.	13,9 - 17,1	50 - 61	31 - 37,9
8	Gale	Some branches break. Generally we cannot walk against the wind.	17,2 - 20,7	62 - 74	38,53 - 45,98
9	Strong gale	The wind causes slight damage to buildings. Tiles and chimney stacks are blown off.	20,8 - 24,4	75 - 88	46,60 - 54,68

A- Foreword

2.1.4 - Risk of electric shock (electrocution)



Risk of death or serious injuries

The machine is not electrically insulated and does not provide protection from contact or proximity to electrically charged conductors.

Always position all parts of the aerial work platform, the occupants, accessories and tools at a reasonable distance from power lines to ensure that no part of the work platform accidentally comes into contact with a power line.

Apply local regulations pertaining to safety distances. If this is not possible, follow the distances in the table below at a minimum :

Minimum safe approach distances

Electric voltage	Minimum safety distance	
	Mètre	Feet
0 - 300 V	Avoid contact	
300 V - 50 kV	3	10
50 - 200 kV	5	15
200 - 350 kV	6	20
350 - 500 kV	8	25
500 - 750 kV	11	35
750 - 1000 kV	14	45

- Do not operate the machine when close to live power lines, consider the movement of the machine and the sway of the electric power lines particularly in windy conditions.
- Do not operate the machine during lightning, thunderstorms, snow/ice or any weather condition that could compromise operator safety.
- Do not use the machine as a ground for welding.
- Do not weld on the machine without first disconnecting the battery terminals.
- Always disconnect ground cable first.
- The machine must not be used while charging the batteries.
- When using the AC power supply, ensure it is protected with a circuit breaker and residual current device.

Keep away from the machine if it contacts energized power lines. Personnel on the ground or in the platform must not touch or operate the machine until energized power lines are shut off.



A- Foreword

2.1.5 - Explosion / Fire Hazards

- Always wear protective clothing and eye wear when working with batteries and power sources/systems.

N.B.:-ACID IS NEUTRALIZED WITH SODIUM BICARBONATE AND WATER.

- Do not start the engine if you smell or detect liquid propane gas (LPG), gasoline, diesel fuel or other explosive substances.



Do not work on or operate a machine in an explosive or flammable atmosphere / environment.

- Do not touch hot components.
- Do not bridge the battery terminals with metallic objects.
- Do not service the battery in proximity of spark, open flame, lit cigarettes.
- Do not fill up the fuel tank, when the engine is running and/or near a flame.



A

B

C

D

E

F

G

H

I





A- Foreword

2.1.6 - Crushing / Collision Hazards

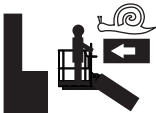

Before using the machine, mark out the machine's work and circulation area using a marking system appropriate to the task at hand and the work environment.

When in the platform :

- Check the work area for overhead clearance, for any obstacles besides and below the platform when raising/lowering the platform and or before driving.
- 
- 
- During movement, keep all the parts of the body inside the platform. Hold onto the guardrails on the opposite side to any surrounding structures. Take care to avoid trapping hands whilst holding the guardrails.
 - To position machine close to a building/structure, it is recommended using the upper boom and or arms movement control functions to position, rather than driving machine closer to structure.
- 
- 
- Warn personnel not to work, stand, or walk under a raised boom/platform.
 - Be aware of the boom position and tail swing when rotating the turret (turntable).
 - Always ensure that the chassis is never kept any closer than 1 m (3 ft 3 in) to holes, bumps, slopes, obstructions, debris and ground coverings that may hide holes and other dangers.
 - Keep non-operating personnel at least 5 m (16 ft 5 in) away from the machine when driving and slewing.
 - Be aware of driving direction.
 - When turret is slewed/rotated 180°, the platform is now facing the rear of the machine.
 - Check the driving direction with the help of the red or white arrows on the chassis and the platform control box.
 - Also note that when changing the driving direction (Forward <=> Reverse) the joysticks or switches must return to the neutral position before reversing the drive direction and for movement to occur.
 - When driving, position the platform so as to provide the best possible visibility and to avoid any blind spots.
 - Hold on securely to the guardrails.

A - Foreword

- Personal Protection Equipment (EPI) :
 - The occupants of the aerial work platform must wear personal protection equipment and comply with local regulations in force.
 - Operators must comply with the safety standards of the job site and the employer, as well as the applicable state regulations relating to the use of personal protective equipment.
 - All personal fall protection equipment (PFPE) must comply with current regulations, must be inspected and used in accordance with the manufacturer's instructions.
- Avoid contact with fixed or mobile obstacles (other machines).
- Other machines (crane, aerial work platform, etc.) operating in the work area increase the risk of crushing or collision. Restrict the operation of machines moving within the aerial work platform work area.
- Take into consideration the stopping distance, reduced visibility and blind spots of the machine.
- Limit travel speed to suit the ground surface condition, slope (incline), and people in the vicinity.

2.1.7 - Risk of involuntary movements

Never use a damaged or malfunctioning machine.

Always respect the following rules :

- Maintain clearance from high voltage lines.
- Maintain clearance from generators, radar, electromagnetic fields.
- Never expose the batteries or electrical components to water (high pressure washer, rain).

3 - Safety inquiries

Inquiries relating to design criteria/specifications of a product, standards compliance, or overall machine safety should be sent to the HAULOTTE® PRODUCT SAFETY department.

Each inquiry or request should include all relevant information; including contact name, telephone number, mailing address, email address, plus the machine model and serial number.

The HAULOTTE® Product Safety department will evaluate each request/inquiry and will provide a written response.

A - Foreword

4 - Incident notification

Notify HAULOTTE® immediately when a HAULOTTE® product has been involved in an incident/accident leading to personal injury or death, or when there is a major property damage.

HAULOTTE Group - EUROPE Product Safety Department	HAULOTTE Group - Australia, India and Asia Product Safety Department	HAULOTTE Group - North & South America Product Safety Department
Address : Rue Emile Zola - 42420 Lorette - France	Address : No.26 Changi North Way - Singapore 498812 - Singapore	Address : 3409 Chandler Creek Rd. - Virginia Beach, VA 23453 - United States
Tel : +33 (0)4 77 29 24 24	Tel : +65 6546 0123	Tel : +1 757 689 2146
Email : productsafety.europe@haulotte.com	Email : productysafety.apac@haulotte.com	Email : productsafety.americas@haulotte.com

Connect to our website : www.haulotte.com



A - Foreword

5 - Compliance

5.1 - PRODUCT MODIFICATION

It is strictly forbidden to modify a HAULOTTE® product. Any modification may violate Haulotte design parameters, local regulations and industry standards.

Any requests for modification must be formulated in writing (form) and be approved by the manufacturer.

Do not hesitate to contact HAULOTTE Services®, should you have any questions relating to the issued bulletin(s) or with questions on the policy itself.

5.1.1 - Implementing manufacturer safety campaigns

It is essential to implement the safety campaigns issued by the manufacturer. All of these campaigns are accessible on our website.

Connect to our website : www.haulotte.com



Never market (or sell) a machine without first having carried out all of the safety campaigns.

5.2 - PRODUCT SPECIFICATIONS

HAULOTTE® cannot be held liable for any changes to the technical characteristics/specifications contained in this manual. HAULOTTE® has a continuous improvement policy in place for its product range. Given this policy, the Company reserves the right to modify products technical characteristics / specifications without notice.

A- Foreword

5.3 - CHANGE OF OWNERSHIP NOTIFICATION

It is important and necessary to keep HAULOTTE Services® updated with current ownership of the machine. This way, HAULOTTE® will be able to provide the necessary support for the product. If you have sold or transferred this machine(s); it is your responsibility to notify HAULOTTE Services®. It is not required to include Lessees/Renters of Leased/Rented machines on this form.

Connect to our website : www.haulotte.com



A - Foreword

5.4 - DECLARATION OF CONFORMITY



The CE declarations of conformity only apply to machines that have been approved and commissioned within the European Community (EC).

Declaration of conformity - Thermal platforms



**DECLARATION CE DE CONFORMITE
(EC DECLARATION OF CONFORMITY)**



<p>Fabricant et personne autorisée à constituer le dossier technique <i>(Manufacturer and the person authorised to compile the technical file):</i></p> <p>HAULOTTE GROUP</p> <p>Adresse du site de production <i>(Address of the Division)</i></p> <p>en conformité avec le modèle type <i>(In compliance with the Model Type)</i></p> <p>Nom commercial <i>(Commercial name)</i></p> <p>Numéro de série <i>(Serial number)</i></p> <p>Organisme notifié <i>(Notified body)</i></p> <p>Numéro de certificat <i>(Certificate number)</i></p> <p>Charge maximale d'utilisation <i>(Rated capacity)</i></p>	<p>Compliance & Regulation Director HAULOTTE GROUP S.A. RUE EMILE ZOLA 42420 LORETTE FRANCE</p> <p>Nacelle élévatrice de personnel <i>(Mobile Elevating Work Platform)</i></p> <p>Modèle type de la machine concernée <i>(Type model of the concerned machine)</i></p> <p>Nom commercial de la machine concernée <i>(Commercial name of the concerned machine)</i></p> <p>Numéro de série de la machine concernée <i>(Serial number of the concerned machine)</i></p> <p>Nom et adresse de l'organisme notifié <i>(Name and address of notified body)</i></p> <p>Numéro de certificat du type de machine <i>(Certificate number of type of machine)</i></p> <p>Charge maximale d'utilisation de la machine concernée <i>(Rated capacity of the concerned machine)</i></p>
--	---

Nous déclarons que cette machine est conforme aux dispositions des Directives suivantes
(We hereby declare that this machine conforms with all the relevant provisions of the Directives listed below)

Directive CE Machine <i>(EC Machinery Directive)</i>	2006/42/CE
Se conforme aux principales exigences de la norme harmonisée <i>(This machine also fulfils the principles of the harmonised standard)</i>	EN280:2013 + A1:2015
Directive CE concernant la compatibilité électromagnétique <i>(EC Directive on electromagnetic compatibility)</i>	2014/30/EU
Directive CE RED concernant les équipements radioélectriques (si la machine est équipée) <i>(RED EC Directive on radio-electrical equipment (if machine equipped))</i>	
Directive CE d'émission de bruit <i>(EC Outdoor Noise Directive)</i>	2000/14/EC
Méthode de mesure <i>(Measurement method)</i>	Annex III-B
Niveau de puissance acoustique garanti <i>(LWA, Guaranteed sound level)</i>	101 dB
Niveau de puissance acoustique mesuré max <i>(LWA, Maximum sound level)</i>	99 dB

Cette déclaration porte exclusivement sur la machine dans l'état où elle a été placée sur le marché
(This declaration relates exclusively to the machinery in the state in which it was placed on the market)

Toute modification de la machine décrite ci-dessus a pour effet d'invalider cette déclaration
(Any modification to the above described machine violates the validity of this declaration)

Nom et signature du Directeur du site de production <i>(Name and signature of the Division Director)</i>	Lieu <i>(Place)</i>
	Date <i>(Date)</i>

haulotte.com

A- Foreword



The UK declarations of conformity only apply to machines that have been approved and commissioned within the United Kingdom (UK).

Declaration of conformity - Thermal platforms

Haulotte

UKCA DECLARATION OF CONFORMITY

Manufacturer and the person authorised to compile the technical file:

HAULOTTE GROUP

France

Certificate number

Rated Capacity



Nathalie Reynolds
General Manager UK and Ireland
Haulotte UK Ltd

Unit 1 Gravelly Way, Four Ashes
Wolverhampton, West Midlands WV10 7GW
ENGLAND

Mobile Elevating Work Platform

In compliance with the Model Type

Commercial name

Serial number

Approved body

This machine also fulfils the principles of the designed standards

Electromagnetic compatibility

Radio equipment (if machinery equipped)

Noise emission in the environment for use outdoors

Measurement method

LWA, Guaranteed sound level

LWA, Maximum sound level

Model Type of the concerned machine

Commercial name of the concerned machine

Serial number of the machine

Rated capacity of the concerned machine

We hereby declare that this machine conforms with all the relevant provisions of the Regulations listed below

Supply of Machinery (safety)	2008
This machine also fulfils the principles of the designed standards	
BS EN280 : 2013 + A1 : 2015	
Electromagnetic compatibility	2016
Radio equipment (if machinery equipped)	2017
Noise emission in the environment for use outdoors	2001

This declaration relates exclusively to the machinery in the state in which it was placed on the market

Any modification to the above described machine violates the validity of this declaration

Name and signature division director

Date and place

haulotte.com

B - Familiarization

1 - General safety

1.1 - INTENDED USE

Do not operate the product in the following situations :

- On soft, unstable or cluttered ground.
- With wind blowing faster than the permissible limit :
 - Check the allowable wind speed specified in the performance specifications tabulation.
 - Consult the Beaufort scale.
- Close to power lines. Keep a safe distance.
- If the machine is stored at a temperature out of range - 20°C / + 50°C (- 4°F / + 122°F).
- In an explosive atmosphere / environment.
- During storms.
- In the presence of strong electromagnetic fields.

N.B.-:USE THE MACHINE UNDER "NORMAL" CLIMATIC CONDITIONS. IF YOU NEED TO USE THE MACHINE IN CLIMATIC CONDITIONS LIKELY TO CAUSE DETERIORATION (EXTREME : HUMIDITY, TEMPERATURES, SALINITY, CORROSIVENESS, ATMOSPHERIC PRESSURE), CONTACT HAULOTTE SERVICES®. REDUCE INTERVALS BETWEEN SERVICING.

N.B.-:IN HARSH ENVIRONMENTS (HIGH LEVELS OF SALINITY IN THE ATMOSPHERE: CLOSE TO THE SEA, INDUSTRIAL ENVIRONMENT WITH CHLORIDE EMISSIONS AND/OR HUMIDITY > 70%), WE RECOMMEND APPLYING SOLVENT-BASED OIL TO THE ENTIRE MACHINE.

N.B.-:WHILE THE MACHINE IS NOT IN USE, CARE MUST BE TAKEN TO BRING THE MACHINE TO THE FULLY STOWED POSITION. ENSURE THAT THE MACHINE IS LOCKED IN A SECURE LOCATION, AND THE CONTROL KEY IS REMOVED TO PREVENT UNAUTHORISED USE OF THE MACHINE.

B - Familiarization

1.2 - DECAL CONTENT

The purpose of the labels on the machine is to alert the user to the conditions of use and risks related to aerial work platforms.

Decals provide the following information :

- The level of severity.
- The specific hazard.
- A method to avoid, suppress or reduce the hazard.
- Descriptive text (where required).

Familiarize yourself with the decals and the hazard severity levels.

The labels must be kept in good condition, otherwise they must be replaced.

Familiarize yourself with the decals and their respective color codes.

Additional decals can be ordered from HAULOTTE Services®.

CE, UKCA and AS standards



ANSI and CSA standards









Marking	Description
1	Hazard symbol
2	Level of severity
3	Avoidance symbol pictorial
4	Avoidance text

B - Familiarization











1.3 - SYMBOLS AND COLORS

Symbols and colors are used to alert the operator of safety precautions and/or to highlight important safety information.

The following safety symbols are used throughout this manual to indicate specific hazards and the hazard severity level when operating or maintaining the Aerial Work Platform.

Symbol	Description
	Danger : Risk of injury or death
	Caution : Risk of material damage
	Prohibited action
	Reminder to use good practice or follow pre-operation checks
	Cross-reference to another part of the manual
	Cross-reference to another manual
	Cross-reference to repair (contact HAULOTTE Services®)
N.B. :	Additional technical information

1.4 - LEVEL OF SEVERITY



































Color	Title	Description
		Danger : Indicates a hazardous situation which if not avoided, WILL result in death or serious injury.
		Warning : Indicates a hazardous situation which if not avoided, COULD result in death or serious injury.
		Caution : Failure to comply could result in minor or moderate injury.
		Notice : Indicates recommended practices if not followed, may result in a malfunction or damage the machine or its components.
		Procedure : Indicates a maintenance operation.

B- Familiarization

1.5 - SYMBOLS LEGEND AND DEFINITIONS

Symbols are used throughout this manual to depict hazards, avoidance measures and indicate when information is required.

Refer to the following table to familiarize yourself with these symbols.

Symbol	Description	Symbol	Description	Symbol	Description
	Risk of crushing or pinning		Foot crushing hazard		High pressure fluid ejection hazard
			Hand crushing hazard		Crushing hazard
			Health/safety hazards related to chemicals		Burn hazard
	Risk of electrocution		Burns and scalds from contact with flames, explosion or radiation from heat sources		Injury from Electric arcs - Energy supply disconnecting devices - Batteries fire, emissions, etc
	Fall hazard		Tip over due to excessive loading / wind load and excessive ground slope		Relate and coordinate directional arrows on the chassis with those on the control box
	Do not put foot in this area		Do not put your hand in this area		Keep away from product working area
	Use of high-pressure cleaners prohibited		Ensure entry drop rail is down		
	Flames prohibited		Maintain safe clearance from high voltage electrically charged conductors as described in manual - Do not use in thunderstorms		Overload
	Refer to operator manual		Safety belt		Use appropriate lanyard attached to dedicated anchor point.
	Wheel pressure		Enable switch		Use safety prop before attempting any maintenance work
	Tow point		Tie down point		Lift point
	Keep away from hot surfaces		Wear protective equipment		

B - Familiarization

2 - Models description

Models	Regulations						
	CE	UKCA	ANSI	CSA	EAC	AS	JIS
HA20RTJ	✓	✓	✗	✗	✓	✓	✓
HA20RTJO	✓	✓	✗	✗	✓	✓	✓
HA20RTJ PRO	✓	✓	✗	✗	✓	✓	✓
HA61RTJO	✗	✗	✓	✓	✗	✗	✗
HA61RTJ PRO	✗	✗	✓	✓	✗	✗	✗

Legend

✓	Available
✗	Not available

B - Familiarization

3 - Primary machine components

3.1 - GROUND CONTROL BOX

3.1.1 - Layout

General view

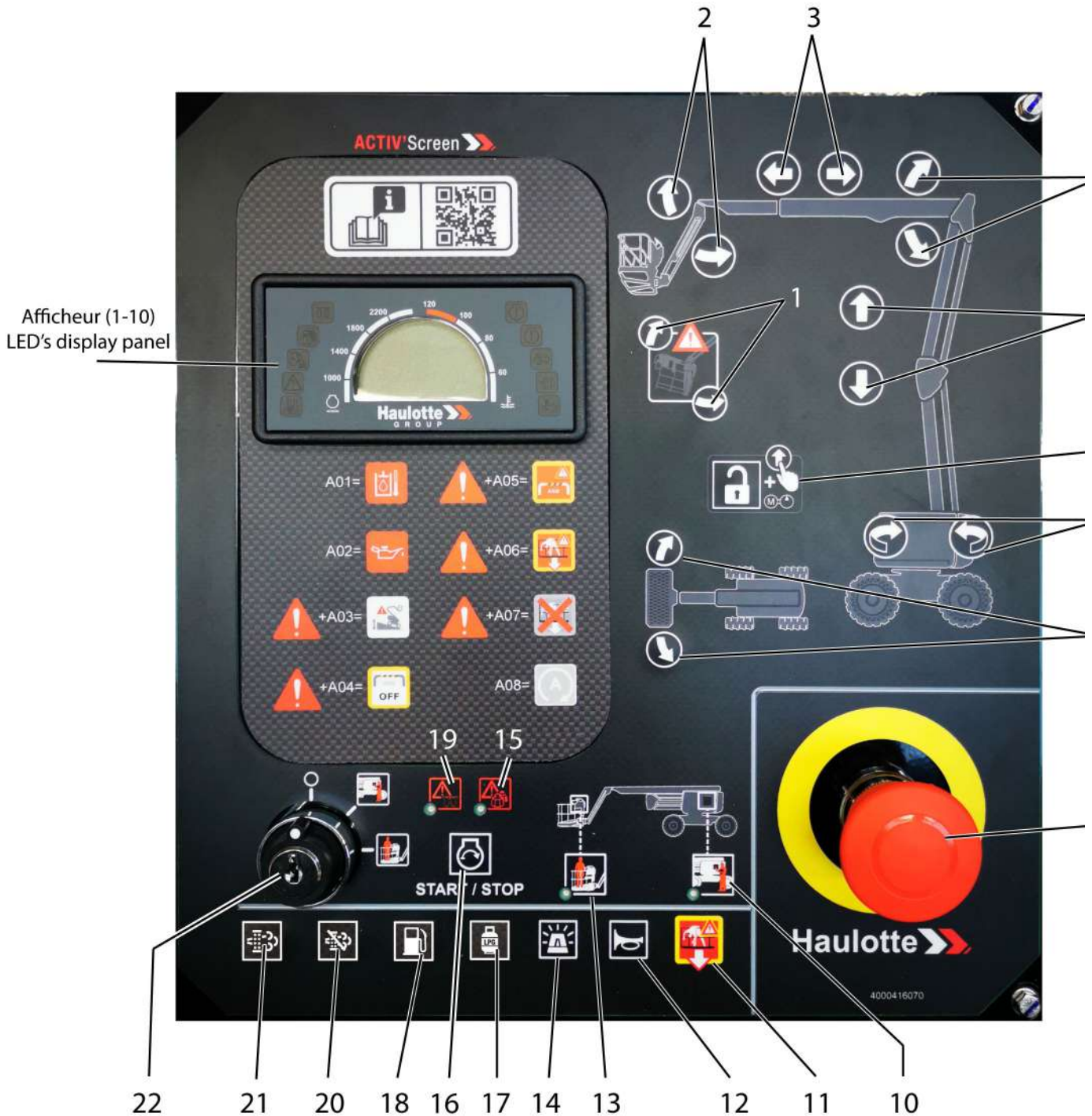









B - Familiarization





Controls and indicators

Marking	Name	Description	Function
1		Platform tilt control	By pressing on  : Tilt the platform towards the front of the machine
			By pressing on  : Tilt the platform towards the back of the machine
2	SA620U	Jib raising / lowering switch ¹	By pressing on  : Jib raising
	SA620D		By pressing on  : Jib lowering
3	SA530O	Boom telescoping switch	By pressing on  : Boom extending
	SA530I		By pressing on  : Boom retracting
4	SA520U	Boom raising / lowering switch	By pressing on  : Boom raising
	SA520D		By pressing on  : Boom lowering
5	SA420U	Arm raising / lowering switch	By pressing on  : Arm raising
	SA420D		By pressing on  : Arm lowering
6	SB800	Enable Switch / Back-up unit selector	By pressing on  : <ul style="list-style-type: none"> • Validation of controls when engine started • automatic switching of emergency electropump if the engine is stopped
7	SA250L	Turntable rotation switch	By pressing on  : Counter clockwise (CCW) rotation
	SA250R		By pressing on  : Clockwise (CW) rotation
8	SA750L	Platform rotation switch	By pressing on  : Clockwise (CW) rotation
	SA750R		By pressing on  : Counter clockwise (CCW) rotation
9	SB801	E-stop button	Pulled out : Ground control box energized Pushed in (activated) : De-energizes control system

B - Familiarization

Marking	Name	Description	Function
10	HL905	Indicator, ground control box selected	LED lights up - ground control box icon
11	SA801	"Overriding system" control	By pressing on  : Authorize movements from the ground control box in case of overload (Use ONLY in case of emergency)
12	SB807	Horn button	By pressing on  : Horn activation
13	HL906	Indicator of the platform control box selection	LED lights up - platform control box icon
14	SA903	Beacon light on/off	By pressing on  : Beacon light ON / OFF
15	HL909	Overload indicator	Alarm icon  : <ul style="list-style-type: none"> • Flashes when the machine starts at the same time as the (19) icon • Is blinking if overriding is active : • If there is a fault, an error code will be displayed on the Activ' Screen • Or Hydraulic oil temperature icon is active on the Activ' Screen • Or Engine pressure icon is active on the Activ' Screen • Or Engine stop icon is active on the Activ' Screen • Or Overload machine status is active on the Activ' Screen
16	SA303	Engine start-up selector	By pressing on  : Engine start / stop
17	SA300	Propane Gas supply ²	By pressing on  : Propane Gas supply selection
18	SA305	Petrol/Gasoline or diesel supply ³	By pressing on  : Fuel supply selection
19	HL908	Engine warning indicator / Engine pre-heating	Alarm icon  : <ul style="list-style-type: none"> • Flashes when the machine starts at the same time as the (15) icon • Is blinking if overriding is active Warning icon is ON if : • Engine warning icon will be displayed on the Activ' Screen • Or Tilt machine status will be displayed on the Activ' Screen • Or Engine is pre-heating
20	SA600F	DPF regeneration inhibited ⁴	By pressing on  : Refusal of the request for regeneration

B - Familiarization

Marking	Name	Description	Function
21	SA600D	DPF regeneration required ⁵	By pressing on  : Regeneration start-up
22	SA900	Control box activation key switch	 : De-energizes control system
			 : Platform control box energized
			 : Ground control box energized
23		Activ'Screen 2	

1. For machines fitted with
2. For machines fitted with
3. For machines fitted with
4. For machines fitted with
5. For machines fitted with

A

B

C

D

E

F

G

H

I

B- Familiarization

3.1.2 - Display Panel (LED'S 1 - 10)







Display



Marking	Description
LED 1	Overriding system : • Remains on if the Overriding (11) system command is activated
LED 2	Fault : • Rapid flashing if a fault is active (current defect) • Rapid flashing if an alarm code is activated (From A03 to A07) • Flashing if the service counter is at zero
LED 3	Radius limitation : • Not used
LED 4	Overload • Flashing : Faulty weighing system • Flashing if overloaded
LED 5	Combustion engine pre-heating : • Illuminated while engine is pre-heating • Off if engine started and if post-heating
LED 6	Engine warning : • Flashing : 5 flashes when ignition is switched on if service counter is less than 25 hours • Constantly on : If the service counter is at zero
LED 7	Engine shutdown : • Lighted in case of major engine fault (e.g. engine overheating, oil pressure, alternator fault, etc.) • Lighted in case of faults managed by the engine ECU
LED 8 ¹	DPF regeneration inhibited (DPF : Diesel Particulate Filter)
LED 9 ²	DPF regeneration required : • Permanently lighted if the particle filter requires regeneration with a high clogging level (DPF : Diesel Particulate Filter)
LED 10 ³	DPF regeneration in progress, high temperature in the exhaust system (HEST) (HEST : High Exhaust System Temperature)

1. If engine equipped with Particulate Filter Regeneration
2. If engine equipped with Particulate Filter Regeneration
3. If engine equipped with Particulate Filter Regeneration

B - Familiarization

Symbol	Description
	Illuminated when service counter is displayed
	<ul style="list-style-type: none"> • Illuminated when engine is not running or when hour meter is displayed • Flashing engine in operation
	Low fuel level
	Illuminated when engine is not running, or if the engine is running and there is an alternator fault
	<p>Display of service counter for 3 s when the machine is switched on, then display of the hour meter for 3 s.</p> <p>Then</p> <ol style="list-style-type: none"> 1. Display of one or more faults, if present, with scrolling of faults every 2 s 2. Display of service counter if it is at zero 3. Display of hour meter
	Indicates the engine speed
	<ul style="list-style-type: none"> • Indicates engine temperature, if available on the engine





B - Familiarization

3.1.2.1 - Fault and alarm codes

Failures codes







Failure code F01.xx	Fault - Variator	Failure code F09.xx	Fault - IC Engine
Failure code F02.xx	Fault - power contactor	Failure code F10.xx	Fault - Functions
Failure code F03.xx	Fault - command relay	Failure code F11.xx	Fault - machine safety
Failure code F04.xx	Fault - electro-valve	Failure code F12.xx	Fault - electronic control unit ECU
Failure code F05.xx	Fault - joystick	Failure code F13.xx	Fault - Switches
Failure code F06.xx	Fault - weight management system	Failure code F14.xx	Fault - Driving pump
Failure code F07.xx	Fault - limit switch or sensor	Failure code F15.xx	Fault - data communication system CAN
Failure code F08.xx	Fault - electrical circuit	Failure code F16.xx	Fault - Electric motor

Alarm codes

A01		Hydraulic oil temperature	Icon is ON when the temperature in the hydraulic reservoir has exceeded the maximum required temperature. Stop using the machine and allow the oil to cool down.
A02		Engine oil pressure	Icon is ON if engine oil pressure is lower than required limit while engine is running. The Engine must be switched OFF immediately to avoid damaging the motor.
A03		Tilt	The machine is elevated, and is on a slope greater than the permitted slope. Depending on the machine configuration, the lifting and extension functions are slowed or stopped.
A04		Activ' Shield Bar disable	The secondary safety system is switched off.

B - Familiarization

Alarm codes

A05		Activ' Shield Bar triggered	 <p>The secondary safety system is triggered. An operator may be trapped on the platform :</p> <ul style="list-style-type: none"> • In this situation, supervisor(s) at ground level must turn the control box key selector (22) to the ground control box  position to take control. • The platform box controls are now de-energizedThe platform box controls are now de-energized. • Check that the E-Stop button (9) at ground is not pressed in. • To safely activate movements from the ground control box, the Enable Switch (6)  must be pressed and held.
A06		<p>Emergency mode is activated when :</p> <ul style="list-style-type: none"> • The E-Stop at platform control box is pushed in (de-energized). • The machine is in overload state. • Ground control box is selected/energized. • The emergency overriding button is activated. 	
A07		The Emergency mode is out of service/non-functional	
A08		Stop Emission System	<ul style="list-style-type: none"> • The icon is ON if the system is active on the machine

N.B.-:-IF SEVERAL ALARM CODES ARE ACTIVE, THEY SCROLL SEQUENTIALLY EVERY 3 SECONDS ON THE DISPLAY. CODES A05 AND A06 TAKE PRIORITY OVER THE OTHER ALARM CODES, AND IN THIS CASE, ONLY THE PRIORITY CODE REMAINS ON THE DISPLAY. CODE A06 TAKES PRIORITY OVER CODE A05 AND IN THIS CASE, ONLY CODE A06 REMAINS ON THE DISPLAY.

B - Familiarization

3.2 - PLATFORM CONTROL BOX

3.2.1 - Layout

General view

Affichage pupitre de commandes haut (Led 101 - 117)

Platform control box display (Led's 101 - 117)

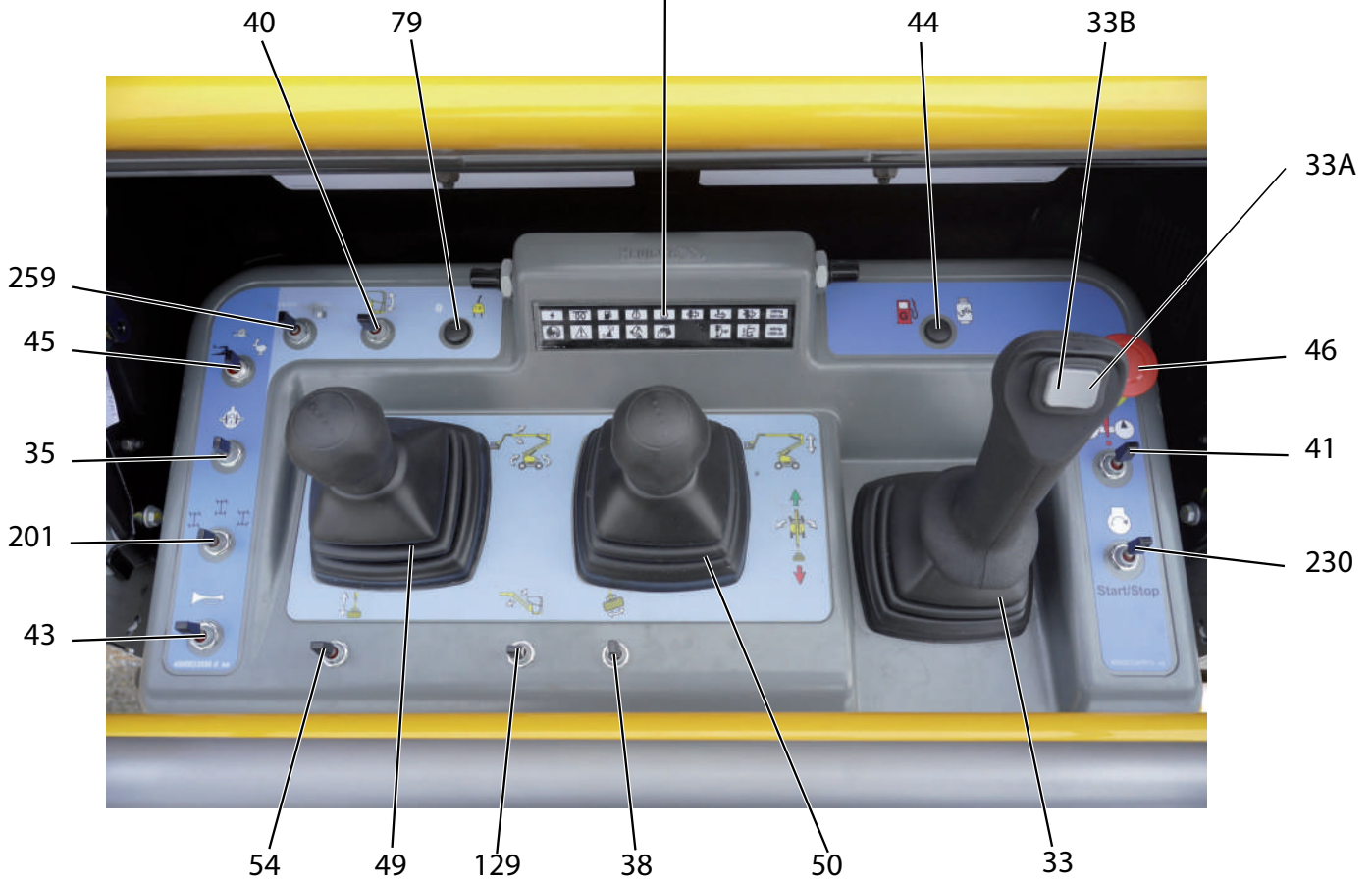

B - Familiarization

Controls and indicators

Marking	Name	Description	Function
33	SM902	Drive joystick	Move forward : Forward drive Move backwards : Reverse drive
33A		Steering button (Steering thumb / rocker switch)	Press right side of button : Steer right - According to selected mode (201)
33B			Press left side of button : Steer left - According to selected mode (201)
35	SA100	Differential lock selector	Toggle left and hold(Activated) : Maximum drive torque (on difficult or sloping ground) Release (deactivated) : Standard torque
38	SA751	Platform rotation switch	Move to the right : Counter clockwise (CCW) rotation Move to the left : Clockwise (CW) rotation
40	SA721	Platform leveling switch	Move upwards : Raise platform Move downwards : Platform lowers
41	SA800	Auxiliary power switch	Toggle and hold : Back-up unit activated Release : Back-up unit deactivated
43	SA907	Horn button	Push the horn selector down to sound the horn The horn stops when the selector switch is released
44	SA304	Fuel selector ¹	Push switch to the right for LPG (liquid propane gas supply) Push switch to the left for gasoline (petrol) or diesel fuel supply
45	SA110	Drive speed selector	 High-speed drive  Medium speed drive  Low-speed drive
46	SB802	E-stop button	Pulled out : Platform control box energized Pressed in : De-energizes control system (Engine stopped)
49	SM900	Turntable rotation joystick	Move to the right : Counter clockwise (CCW) rotation Move to the left : Clockwise (CW) rotation
		Boom lift joystick	Move forward : Raise boom Move backwards : Lower boom
50	SM901	Arm lift joystick	Move forward : Arm raises Move backwards : Arm lowers
54	SA531	Boom telescoping switch	Hold upwards : Boom retracts Move downwards and hold : Boom extends
79	SA906	Generator selector ²	Move to the left : Generator deactivated Move to the right : Generator activated
129	SA621	Jib raising / lowering switch ³	Hold upwards : Lifting Move downwards and hold : Lowering
201	SA101	Steering mode selector ⁴	All 4 wheels steer Front 2 wheels steer Crab mode

B - Familiarization

Marking	Name	Description	Function
230	SA303	Engine start-up / stop selector	Move backwards : Starts or Stops the engine (depending on the engine's operating (ON/OFF) mode

1. For machines fitted with
2. For machines fitted with
3. For machines fitted with
4. For machines fitted with

B - Familiarization





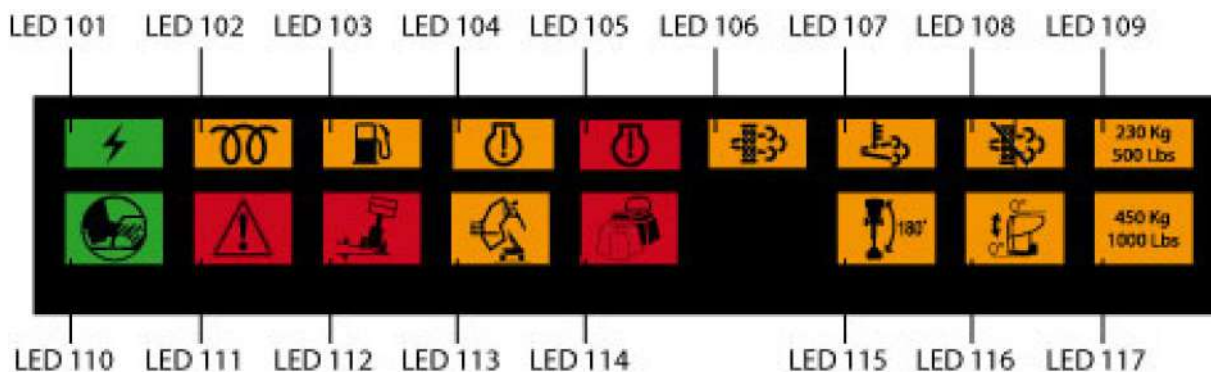

3.2.2 - Display Panel (LED'S 101 - 117)

Upper control box display















Marking	Name	Symbol	Function
LED 101	HL900		Power ON
LED 102	HL300		Combustion engine pre-heating
LED 103	HL307		Low fuel level
LED 104	HL304		Engine warning
LED 105	HL305		Engine shutdown
LED 106	HL301		DPF regeneration required (If equipped)
LED 107	HL302		DPF regeneration in progress, high temperature in the exhaust system (HEST) (If equipped)
LED 108	HL303		DPF regeneration inhibited (If equipped)
LED 109 ¹	HL805		Not used
LED 110	HL807		Foot Switch
LED 111	HL801		Fault

B - Familiarization

Marking	Name	Symbol	Function
LED 112	HL800		Tilt
LED 113	HL804		Not used
LED 114	HL802		Overload
LED 115	HL250		Not used
LED 116	HL720		Platform leveling
LED 117 ²	HL806		Not used

1. If machine equipped with dual load
2. If machine equipped with dual load

B- Familiarization

Symbol	Description
	Machine switched on : <ul style="list-style-type: none"> • Rapid flashing : Machine is ON, but platform control box is not active but the ground control box is ON. Also flashes with either E-stop pressed in • Illuminated : Machine is turned on and platform control panel is active.
	Foot Switch : <ul style="list-style-type: none"> • Illuminated when Foot Switch activated
	Faults : <ul style="list-style-type: none"> • Rapid flashing : If a fault is active (current fault)
	Overload : <ul style="list-style-type: none"> • Rapid flashing : Faulty weighing / overload system • Illuminated when overloaded
	Tilt sensor : <ul style="list-style-type: none"> • Illuminated when in tilt, machine stowed or unfolded
	Basket levelling +/- 10° : <ul style="list-style-type: none"> • Illuminated if the angle of the platform reaches +/- 10° in relation to the horizontal and movement control
	Low fuel level
	Combustion engine pre-heating : <ul style="list-style-type: none"> • Illuminated while engine is pre-heating • Off if engine started and if post-heating
	Engine warning : <ul style="list-style-type: none"> • Lighted in case of minor engine fault (e.g. water in the diesel, clogged air filter, etc.) • Lighted or flashing in case of fault managed by the engine ECU
	Engine shutdown : <ul style="list-style-type: none"> • Lighted in case of major engine fault (e.g. engine overheating, oil pressure, alternator fault, etc.) • Lighted in case of faults managed by the engine ECU
	DPF regeneration required : <ul style="list-style-type: none"> • Permanently lighted if the particle filter requires regeneration with a high clogging level¹
	DPF regeneration in progress, high temperature in the exhaust system (HEST) : ²
	DPF regeneration inhibited³





1. If engine equipped with Particulate Filter Regeneration
2. If engine equipped with Particulate Filter Regeneration
3. If engine equipped with Particulate Filter Regeneration

B - Familiarization



3.3 - DPF (DIESEL PARTICLE FILTER) (IF EQUIPPED)

- The DPF (Diesel Particle Filter) system is designed to remove diesel particulate matter or soot from the exhaust gas of a diesel engine.
- The filter regeneration removes the accumulation of soot from the filter before filter clogs. This is done automatically by increasing the temperature in the filter itself in order to burn the soot.

KUBOTA engine

Machine behaviour			Filter status - Soot loading level					
			Level 0	Level 1	Level 2	Level 3	Level 4	Level 5
Regeneration of diesel particles filter								
Engine derating						ON	ON	ON
Automatic regeneration				ON	ON			
Engine idle speed increased				ON	ON	ON	ON	ON
Active / Manual regeneration / Forced regeneration				Available	Available	Mandatory	Mandatory (Service)	
Indicators								
Ground control box	Platform control box	Description						
	LED 111	Failure : • Flashing				ON	ON	ON
	LED 104	Engine warning (Failure F09.07 is active) : • On				ON	ON	ON
	LED 105	Engine shutdown (Failure F09.08 is active) • On					ON	ON
	LED 106	Diesel particulate filter : • Ground control box • Flashing		ON	ON	ON	ON	ON
	LED 106	Diesel particulate filter : • Platform control box • Flashing				ON	ON	ON

B - Familiarization

Machine behaviour			Filter status - Soot loading level					
			Level 0	Level 1	Level 2	Level 3	Level 4	Level 5
	LED 107	High Exhaust System Temperature (HEST) : • The temperature of the exhaust system is high • On		ON	ON	ON	ON	ON
	LED 107	High Exhaust System Temperature (HEST) : • DPF regeneration in progress, high temperature in the exhaust system • Flashing		ON	ON	ON	ON	ON
	LED 108	To inhibit regeneration : • If inhibit switch is activated • On	ON	ON	ON			
Sounding alarm								
	Ground control box	• Manual regeneration needed				ON	ON	ON
Machine state								
	Machine screen DPF 0	Automatic regeneration : • Engine idle speed increased • Regeneration DPF in progress • Keep working normally		ON	ON			
	Machine screen DPF 1	Manual regeneration : • Regeneration needed • Please launch a manual regeneration • Cut-off unfolding movements				ON		
	Machine screen DPF 2	Manual regeneration : • Regeneration needed • Regeneration to be done by Kubota dealer • Cut-off unfolding movements					ON	
	Machine screen DPF 3	DPF is out of repair : • Regeneration to be done by Kubota dealer • Cut-off unfolding movements						ON

A

B

C

D

E

F

G

H







I

B - Familiarization







Machine behaviour	Filter status - Soot loading level					
	Level 0	Level 1	Level 2	Level 3	Level 4	Level 5
Functions						
Stop Emission System	ON					
Cumulated movement between arm, boom, boom telescope are forbidden				ON	ON	ON
Machine unfolded : • From the ground control box / From the platform control box : • Arm raise, boom raise, boom extension are slowed down				ON	ON	ON
Machine folded : • From the ground control box : • Arm raise, boom raise, boom extension are forbidden • From the platform control box : • Arm raise, boom raise, boom extension are slowed down				ON	ON	ON

B - Familiarization

Kohler engine

Machine behaviour		Filter status - Soot loading level					
		Level 0	Level 1	Level 2	Level 3	Level 4	Level 5
Soot loading level		0 % to 30 %	30 % to 80 %	80 % to 90 %	90 % to 100 %	100 % to 110 %	Above 110 %
Regeneration of diesel particles filter							
Engine derating					ON	ON	ON
Engine shutdown							ON
Automatic regeneration				ON			
Engine idle speed increased				ON	ON	ON	ON
Active / Manual regeneration / Forced regeneration				Available	Mandatory	Mandatory	Mandatory (Service)
Indicators							
Ground control box	Platform control box	Description					
	LED 111	Failure : • Flashing			ON	ON	ON
	LED 104	Engine warning (Failure F09.09 is active) : • On				ON	ON
	LED 105	Engine shutdown (Failure F09.10 is active) : • On					ON
	LED 106	Diesel particulate filter : • Ground control box • Flashing			ON	ON	ON
	LED 106	Diesel particulate filter : • Platform control box • Flashing				ON	ON
	LED 107	High Exhaust System Temperature (HEST) : • The temperature of the exhaust system is high • On			ON	ON	ON

B- Familiarization

Machine behaviour			Filter status - Soot loading level					
			Level 0	Level 1	Level 2	Level 3	Level 4	Level 5
Soot loading level			0 % to 30 %	30 % to 80 %	80 % to 90 %	90 % to 100 %	100 % to 110 %	Above 110 %
	LED 107	High Exhaust System Temperature (HEST) : • DPF regeneration in progress, high temperature in the exhaust system • Flashing			ON	ON	ON	ON
	LED 108	To inhibit regeneration : • If inhibit switch is activated • On	ON	ON	ON			
Sounding alarm								
	Ground control box					ON	ON	ON
Machine state								
	Machine screen DPF 0	Automatic regeneration : • Engine idle speed increased • Regeneration DPF in progress • Keep working normally			ON			
	Machine screen DPF 1	Manual regeneration : • Regeneration needed • Please launch a manual regeneration • Cut-off unfolding movements				ON		
	Machine screen DPF 2	Manual regeneration : • Regeneration needed • Regeneration to be done by Kohler dealer • Cut-off unfolding movements					ON	ON
	Machine screen DPF 3	DPF is out of repair : • Regeneration to be done by Kohler dealer • Cut-off unfolding movements						ON
Functions								

B - Familiarization

Machine behaviour	Filter status - Soot loading level					
	Level 0	Level 1	Level 2	Level 3	Level 4	Level 5
Soot loading level	0 % to 30 %	30 % to 80 %	80 % to 90 %	90 % to 100 %	100 % to 110 %	Above 110 %
Stop Emission System	ON					
Cumulated movement between arm, boom, boom telescope are forbidden				ON	ON	ON
Machine unfolded : • From the ground control box / From the platform control box : • Arm raise, boom raise, boom extension are slowed down				ON	ON	ON
Machine folded : • From the ground control box : • Arm raise, boom raise, boom extension are forbidden • From the platform control box : • Arm raise, boom raise, boom extension are slowed down				ON	ON	ON

B - Familiarization

4 different ways of regeneration are possible.

3.3.1 - Automatic regeneration

The automatic regeneration occurs during normal machine usage without any interruption.





When automatic regeneration is on-going :

1.  icon lights up on ground control box.
2. DPF activation icon HL302 / LED107 on the platform control box display lights up.





3.3.2 - Manual regeneration



The machine cannot be used during the manual regeneration cycle.

1. Park the machine in a safe stowed position outside location and away from other equipment.
2. Check that the fuel level icon  on the ground control box doesn't light-up.
3. Put the engine hood in closed position.
4. Press the regeneration button  on the ground control box and hold for 5 seconds.
5. When regeneration is initiated, the regeneration icon  on the ground control box starts blinking.
6. Engine speed increases to 2300 rpm.
7. The regeneration cycle will take approximately 15 min.
8. When regeneration is complete, all engine lights   on the ground control box are turned off. Engine speed is automatically decreased to idle speed.

3.3.3 - To inhibit regeneration

To inhibit regeneration (indoors or in explosive atmosphere), press button  on ground control box and hold for 5 seconds. The regeneration is inhibited until cancellation. To activate regeneration, press the button  again during 5 seconds. When the regeneration is inhibited,  at ground control box and  at platform control box display light up.

3.3.4 - To stop manual regeneration

Use this function only in case of emergency.

Regeneration process can be stopped by :

- Press the inhibition button  and hold for 5 seconds.

Or

- Press the launching regeneration button  and hold for 5 seconds.

Or

- Initiate any function movement.

B - Familiarization

4 - Performance Specifications

4.1 - TECHNICAL CHARACTERISTICS

Use the table to select the right Haulotte machine for the job.



Do not replace parts that are essential to the stability of the machine, such as batteries or tyres, with parts that have a different weight or different specifications. The stability of the machine could be affected.

CE, UKCA, AS, EAC, CSA and ANSI A92.20 standards

Machine	HA20RTJ		HA20RTJ O - HA61RTJ O	
	SI	Imp.	SI	Imp.
Characteristics - Dimensions				
Maximum working height	20,60 m	67 ft 7 in	20,60 m	67 ft 7 in
Maximum platform height	18,60 m	61,2 ft	18,60 m	61,2 ft
Maximum horizontal reach	12,10 m	39 ft 8 in	12,10 m	39 ft 8 in
Maximum outreach above the ground	11,60 m	38 ft 1 in	11,60 m	38 ft 1 in
Maximum platform height before driving speed restriction	6 m	19 ft 8 in	6 m	19 ft 8 in
Maximum boom articulation point height	8,10 m	26 ft 7 in	8,10 m	26 ft 7 in
Maximum load capacity	230 kg	500 lbs	230 kg	500 lbs
Jib working range	140° (+60° / -80°)			
Basket rotation angle	180° (+ 90° / -90°)			
Boom rotation angle	75°			
Turntable rotation	355° non continuous			
Maximum number of occupants	2			
Maximum wind speed	60 km/h (16,7 m/s)	37 mph (58 ft/s)	60 km/h (16,7 m/s)	37 mph (58 ft/s)
Gradeability	45%			
Sideslope	25%			
Maximum rated slope allowed	5°			
Manual force	400 N - 90 lbf			
Maximum load on wheel	4 950 kgf	10,913 lbf	4 960 kgf	10,935 lbf
Outside turning radius	4,50 m	14 ft 9 in	4,50 m	14 ft 9 in
Inside turning radius	2,40 m	7 ft 10 in	2,40 m	7 ft 10 in
Maximum ground pressure of wheel on paved ground ¹	12,9 kgf/cm ²	183.5 psi	15,3 kgf/cm ²	218 psi
Total weight	9 250 kg	20,393 lbs	9 400 kg	20,723 lbs
Drive speed :				
• Slow speed (Machine elevated)	1,2 km/h	0.75 mph	1,2 km/h	0.75 mph
• Medium speed (Machine elevated)	2,5 km/h	1.55 mph	2,5 km/h	1.55 mph
• High speed (Machine folded/stowed)	5,0 km/h	3.11 mph	5,0 km/h	3.11 mph
Maximum freewheel speed during towed operation	5,0 km/h	3.11 mph	5,0 km/h	3.11 mph
Engine - Tier III				
Engine type	Kubota V2403 - M - E3 - 36,5 kW - 48,9 hp			
Engine power	36,5 kW - 48,9 hp			
Power consumption	29,4 kW - 39,4 hp			
CO emission	1 g/kWh			

B - Familiarization

Machine	HA20RTJ	HA20RTJ O - HA61RTJ O
HC + NO emission		6,44 g/kWh
Particles emission		0,43 g/kWh
Av fuel consumption		4,5 l/h - 1.19 gal/h
Fuel type		Diesel Fuel Only
Engine - Tier IV		
Engine type	Kubota V2403 - CR - TI - E4B - 48,6 kW - 65,2 hp	
Engine power	48,6 kW - 65,2 hp	
CO emission	0,6 g/kWh	
HC + NO emission	3,7 g/kWh	
Particles emission	0,2 g/kWh	
Av fuel consumption	5 l/h - 1.32 gal/h	
Fuel type	Diesel Fuel Only	
Engine - Tier IV DPF		
Engine type	Kubota V2403 CR - 37,4 kW - 50,2 hp	
Engine power	37,4 kW - 50,2 hp	
CO emission	0,07 g/kWh	
HC + NO emission	2,73 g/kWh	
Particles emission	0,02 g/kWh	
Av fuel consumption	4 l/h - 1.05 gal/h	
Fuel type	Diesel Fuel Only	
Engine - STAGE V - KUBOTA		
Engine type	KUBOTA D1803 CR TE5 - 37 kW - 49,6 hp	
Engine power	37 kW - 49,6 hp	
CO emission	0,032 g/kWh	
HC + NO emission	3,12 g/kWh	
Particles emission	0,0009 g/kWh	
Av fuel consumption	3,4 l/h - 0.89 gal/h	
Fuel type	Diesel Fuel Only	
Engine type	KUBOTA V2403 CR TE5B - 48,6 kW - 65,1 hp	
Engine power	48,6 kW - 65,1 hp	
CO emission	0,032 g/kWh	
HC + NO emission	3,128 g/kWh	
Particles emission	0,0009 g/kWh	
Av fuel consumption	4,6 l/h - 1.21 gal/h	
Fuel type	Diesel Fuel Only	
Engine - STAGE V - KOHLER		
Engine type	KOHLER KDI 1903 TC - 36,5 kW - 50 hp	
Engine power	36,5 kW - 50 hp	
CO emission	0,065 g/kWh	
HC + NO emission	3,57 g/kWh	
Particles emission	0,001 g/kWh	
Av fuel consumption	3,3 l/h - 0,87 gal/h	

B - Familiarization

Machine	HA20RTJ		HA20RTJ O - HA61RTJ O	
Fuel type	Diesel Fuel Only			
Specifications - Performance				
Operating temperature	- 15° C / + 35° C (- 59° F / + 95° F)			
Storage temperature	- 30° C / + 45° C (-22° F / + 113° F)			
Energy storage				
Type of battery	12 V 100 Ah 800A			
Battery amperage	830 A			
Battery voltage	12 V			
Battery capacity	100 Ah			
Hydraulic tank capacity	140 L	37 gal US	140 L	37 gal US
Fuel tank capacity	80 L	21 gal US	80 L	21 gal US

1. The pressure values are given for standard machines without Option

B - Familiarization

Machine	HA20RTJ PRO - HA61RTJ PRO	
Characteristics - Dimensions	SI	Imp.
Maximum working height	20,60 m	67 ft 7 in
Maximum platform height	18,60 m	61,2 ft
Maximum horizontal reach	12,10 m	39 ft 8 in
Maximum outreach above the ground	11,60 m	38 ft 1 in
Maximum platform height before driving speed restriction	6 m	19 ft 8 in
Maximum boom articulation point height	8,10 m	26 ft 7 in
Maximum load capacity	230 kg	500 lbs
Jib working range	140° (+60° / -80°)	
Basket rotation angle	180° (+ 90° / -90°)	
Boom rotation angle	75°	
Turntable rotation	360° Continuous	
Maximum number of occupants	2	
Maximum wind speed	60 km/h (16,7 m/s)	37 mph (58 ft/s)
Gradeability	45%	
Sideslope	25%	
Maximum rated slope allowed	5°	
Manual force	400 N - 90 lbf	
Maximum load on wheel	4 950 kg	11,128 lbs
Outside turning radius - 4WS	3,75 m	12 ft 4 in
Inside turning radius - 4WS	1,75 m	5 ft 9 in
Outside turning radius - 2WS	4,50 m	14 ft 9 in
Inside turning radius - 2WS	2,40 m	7 ft 10 in
Maximum ground pressure of wheel on paved ground ¹	12,9 kg/cm ²	2,70 lb/ft ²
Total weight	9 630 kg	21,230 lbs
Total weight - With sand tires	9 830 kg	21,670 lbs
Drive speed (4WS) :		
• Slow speed (Machine elevated)	1,2 km/h	0.75 mph
• Medium speed (Machine elevated)	2,5 km/h	1.55 mph
• High speed (Machine folded/stowed)	5,0 km/h	3.11 mph
Drive speed (2WS) :		
• Slow speed (Machine elevated)	1,2 km/h	0.75 mph
• Medium speed (Machine elevated)	2,5 km/h	1.55 mph
• High speed (Machine folded/stowed)	5,0 km/h	3.11 mph
Maximum freewheel speed during towed operation	5,0 km/h	3.11 mph
Engine - Tier III		
Engine type	Kubota V2403 - M - E3 - 36,5 kW - 48,9 hp	
Engine power	36,5 kW - 48,9 hp	
Power consumption	29,4 kW - 39,4 hp	
CO emission	1 g/kWh	
HC + NO emission	6,44 g/kWh	
Particles emission	0,43 g/kWh	

B - Familiarization

Machine	HA20RTJ PRO - HA61RTJ PRO
Av fuel consumption	4,5 l/h - 1.19 gal/h
Fuel type	Diesel Fuel Only
Engine - Tier IV	
Engine type	Kubota V2403 - CR - TI - E4B - 48,6 kW - 65,2 hp
Engine power	48,6 kW - 65,2 hp
CO emission	0,6 g/kWh
HC + NO emission	3,7 g/kWh
Particles emission	0,2 g/kWh
Av fuel consumption	5 l/h - 1.32 gal/h
Fuel type	Diesel Fuel Only
Engine - Tier IV DPF	
Engine type	Kubota V2403 CR - 37,4 kW - 50,2 hp
Engine power	37,4 kW - 50,2 hp
CO emission	0,07 g/kWh
HC + NO emission	2,73 g/kWh
Particles emission	0,02 g/kWh
Av fuel consumption	4 l/h - 1,05 gal/h
Fuel type	Diesel Fuel Only
Engine - STAGE V - KUBOTA	
Engine type	KUBOTA D1803 CR TE5 - 37 kW - 49,6 hp
Engine power	37 kW - 49,6 hp
CO emission	0,032 g/kWh
HC + NO emission	3,12 g/kWh
Particles emission	0,0009 g/kWh
Av fuel consumption	3,4 l/h - 0.89 gal/h
Fuel type	Diesel Fuel Only
Engine type	KUBOTA V2403 CR TE5B - 48,6 kW - 65,1 hp
Engine power	48,6 kW - 65,1 hp
CO emission	0,032 g/kWh
HC + NO emission	3,128 g/kWh
Particles emission	0,0009 g/kWh
Av fuel consumption	4,6 l/h - 1.21 gal/h
Fuel type	Diesel Fuel Only
Engine - STAGE V - KOHLER	
Engine type	KOHLER KDI 1903 TC - 36,5 kW - 50 hp
Engine power	36,5 kW - 50 hp
CO emission	0,065 g/kWh
HC + NO emission	3,57 g/kWh
Particles emission	0,001 g/kWh
Av fuel consumption	3,3 l/h - 0,87 gal/h
Fuel type	Diesel Fuel Only
Specifications - Performance	
Operating temperature	- 15° C / + 35° C (- 59° F / + 95° F)

B - Familiarization

Machine	HA20RTJ PRO - HA61RTJ PRO	
Storage temperature	- 30° C / + 45° C (-22° F / + 113° F)	
Energy storage		
Type of battery	12 V 100 Ah 800A	
Battery amperage	830 A	
Battery voltage	12 V	
Battery capacity	100 Ah	
Hydraulic tank capacity	140 L	37 gal US
Fuel tank capacity	80 L	21 gal US

1. The pressure values are given for standard machines without Option

For China only :

HA20RTJ - HA20RTJ PRO - Kubota Engine

环保信息标签		4001070060 a
达到 GB 20891-2014 第三阶段排放标准		生产日期: AA
环保信息公开编号: AB		
基本信息	型号: AC	名称: 高空作业平台
	商标: Haulotte	机械类型: 工程机械
	机械生产企业名称: 欧胜高空升降平台设备制造(常州)有限公司	
	机械进口企业名称: 欧历胜贸易(上海)有限公司	
	发动机型号: AF	燃料喷射系统形式: 泵喷嘴
	发动机生产厂家名称: 久保田	
环保关键零部件	ECU, 喷油泵, 喷油器, 排气消声器	

B - Familiarization

4.2 - WORKING AREA / RANGE OF MOTION

HA20RTJ - HA20RTJ O - HA20RTJ PRO - HA61RTJ O - HA61RTJ PRO

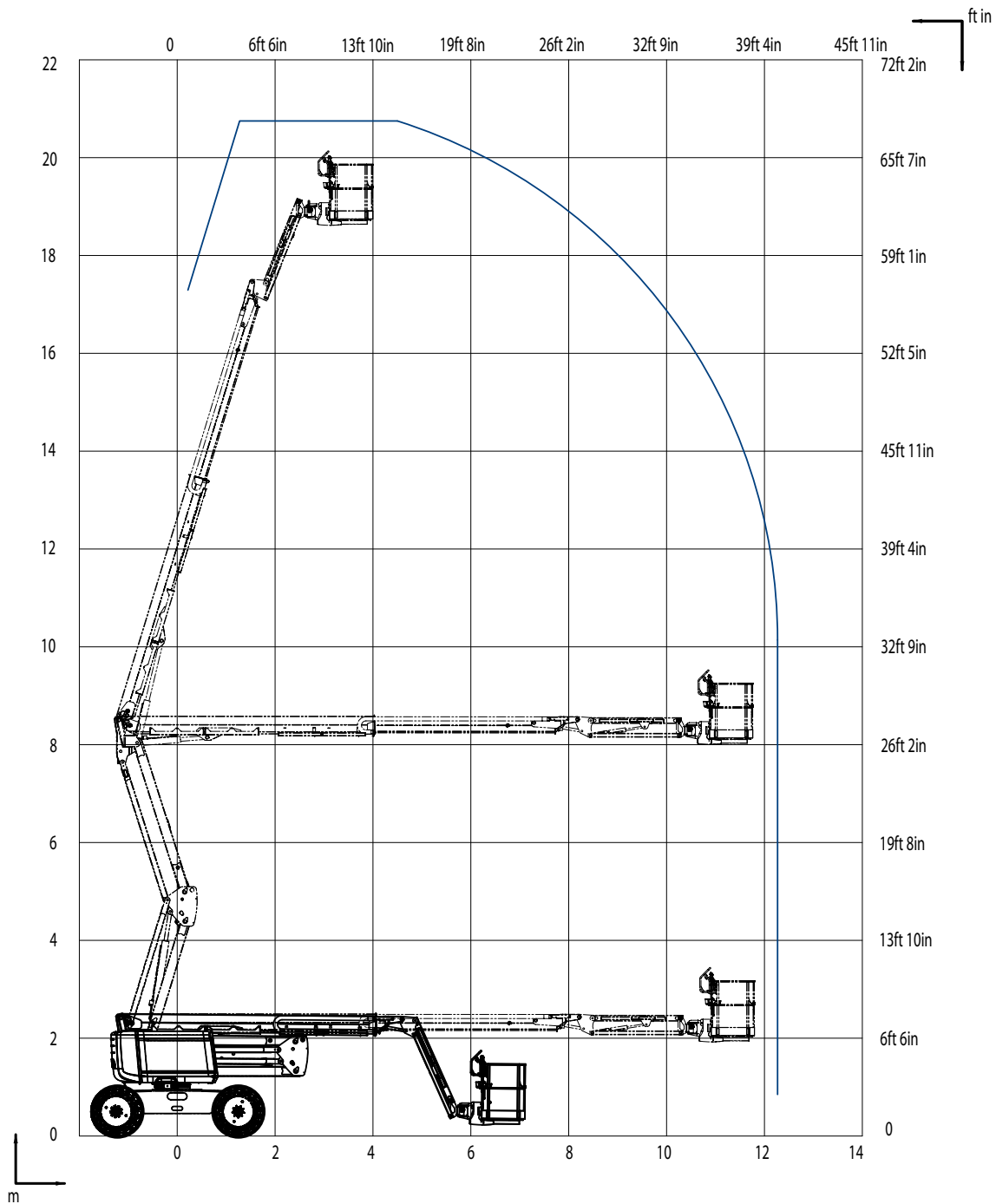

B - Familiarization

CE, UKCA and AS standards - 4000359740 P

Marking	Color	Description	Quantity	HA20RTJ	HA20RTJO	HA20RTJ PRO
1	Red	Height of the floor and load	2	4000701800		
2	Blue	Maximum Pressure per Tire - Floor Loading	4	4000506620	4000359590	
3	Other	Commercial name-Bright machine	1	4000359400	4000359420	4000359440
3	Other	Commercial name-Dark machine	1	4000475740	4000475750	4000475760
4	Other	500 x 100 Decal HAULOTTE®Bright machine	1	307P217080		
4	Other	500 x 100 Decal HAULOTTE®Dark machine	1	307P224740		
4	Other	500 x 100 Decal HAULOTTE®Red machine	1	307P220360		
5	Other	1860 x 280 Decal HAULOTTE®Bright machine	1	4000365570		
5	Other	1860 x 280 Decal HAULOTTE®Dark machine	1	4000390040		
5	Other	1860 x 280 Decal HAULOTTE®Red machine	1	4000390030		
6	Other	Identification plates	1	For CE and AS standards only : 4000700160 UKCA standard only : 4001188820		
8	Other	Noise emission level 101 Db	1	CE standard only : 4000012860		
9	Other	Control of movements - GREEN directional arrow	3	3078143930		
10	Other	Control of movements - RED directional arrow	3	3078143940		
11	Other	Lanyard attachment points - Harness attachment compulsory	9	307P216290		
12	Other	Material risk - Yellow and black adhesive tape	4	4000421700		
14	Red	Risk of crushing - Spindle	1	4000027080		
15	Other	Crown greasing	1	4000025160		
16	Other	Max and min oil level	1	307P221060		
17	Red	Risk of crushing - Do not park	4	4000024800		
18	Orange	Hand crushing hazard - Risk of crushed hands	1	4000024890		
19	Other	Read the operation manual	1	4000025140		

B - Familiarization

Marking	Color	Description	Quantity	HA20RTJ	HA20RTJO	HA20RTJ PRO
20	Red	Operation instructions	1	In german (CE and UKCA standards) : 307P222730 In english (CE, UKCA and AS standards) : 307P222740 In korean (CE, UKCA and AS standards) : 4000618590 In croatian (CE and UKCA standards) : 4000360810 In danish (CE and UKCA standards) : 307P222760 In spanish (CE and UKCA standards) : 307P222770 In estonian (CE and UKCA standards) : 4000360870 In finnish (CE and UKCA standards) : 307P222780 In french (CE standard) : 3078149030 In greek (CE and UKCA standards) : 4000561810 In dutch (CE and UKCA standards) : 307P222790 In hungarian (CE and UKCA standards) : 4000360890 In italian (CE and UKCA standards) : 307P222800 In japanese (CE and UKCA standards) : 4000359830 In latvian (CE and UKCA standards) : 4000359840 In lithuanian (CE and UKCA standards) : 4000359850 In norwegian (CE and UKCA standards) : 4000359900 In polish (CE and UKCA standards) : 4000359860 In portuguese (CE and UKCA standards) : 307P222810 In romanian (CE and UKCA standards) : 4000359870 In Russian (CE and UKCA standards) : 4000359920 In slovakian (CE and UKCA standards) : 4000359880 In slovenian (CE and UKCA standards) : 4000359890 In swedish (CE and UKCA standards) : 307P222820 In ukrainian (CE and UKCA standards) : 4000359910		
22	Orange	Risk of crushing - Do not place foot	2	4000027090		
23	Red	Risk of crushing - Driving direction	1	4000024690		
24	Red	Danger of electrocution	2	For CE and UKCA standards only : 4000025070 AS standard only : 4000227500		
25	Red	Risk of crushing - Closing drop rail	1	4000025080		
26	Red	Danger of electrocution - Platform - Ground for welding	1	4000027100		
27	Other	Tilt verification	1	4000027110		
28	Other	Do not interchange	1	4000504670		

B - Familiarization

Marking	Color	Description	Quantity	HA20RTJ	HA20RTJO	HA20RTJ PRO
32	Blue	Towing anchorage point	6		4000027310	
33	Blue	Lifting anchorage point	4		4000027330	
34	Red	Electric Shock Hazards - Water projection	1		4000025130	
36	Red	Risk of crushing - Platform	1		4000027460	
37	Red	Risks of explosion	1		4000027370	
38	Orange	Hand crushing hazard - Heat burns	1		4000027450	
39	Other	Oil CJ 4 (if fitted)	1		4000019700	
40	Orange	Hand crushing hazard - Snapping up	1		4000027430	
41	Yellow	Revolving cradle	1		3078151730	
47	Blue	Information - Explanation - LOW SULFUR - For Tier IV only	1		307P232480	
49	Blue	Battery +	1		4000071960	
50	Blue	Battery -	1		4000071970	
51	Yellow	Socket - 240 V	1		4000027120	
68	Other	Transport height	1		4000417480	
78	Other	QR Code ( https://www.e.technical-information.com)	1		4001089310	
82	Other	Regeneration of diesel particles filter (STAGE V engine only)	1	For CE and UKCA standards only	4001075370	
200	Other	Made in Europe	1	For CE and UKCA standards only :	4000137690	
201	Red	Wearing of a safety harness is essential	2	AS standard only :	3078144520	

B - Familiarization

EAC standard - 4000423690 F - HA20RTJ - HA20RTJ O - HA20RTJ PRO

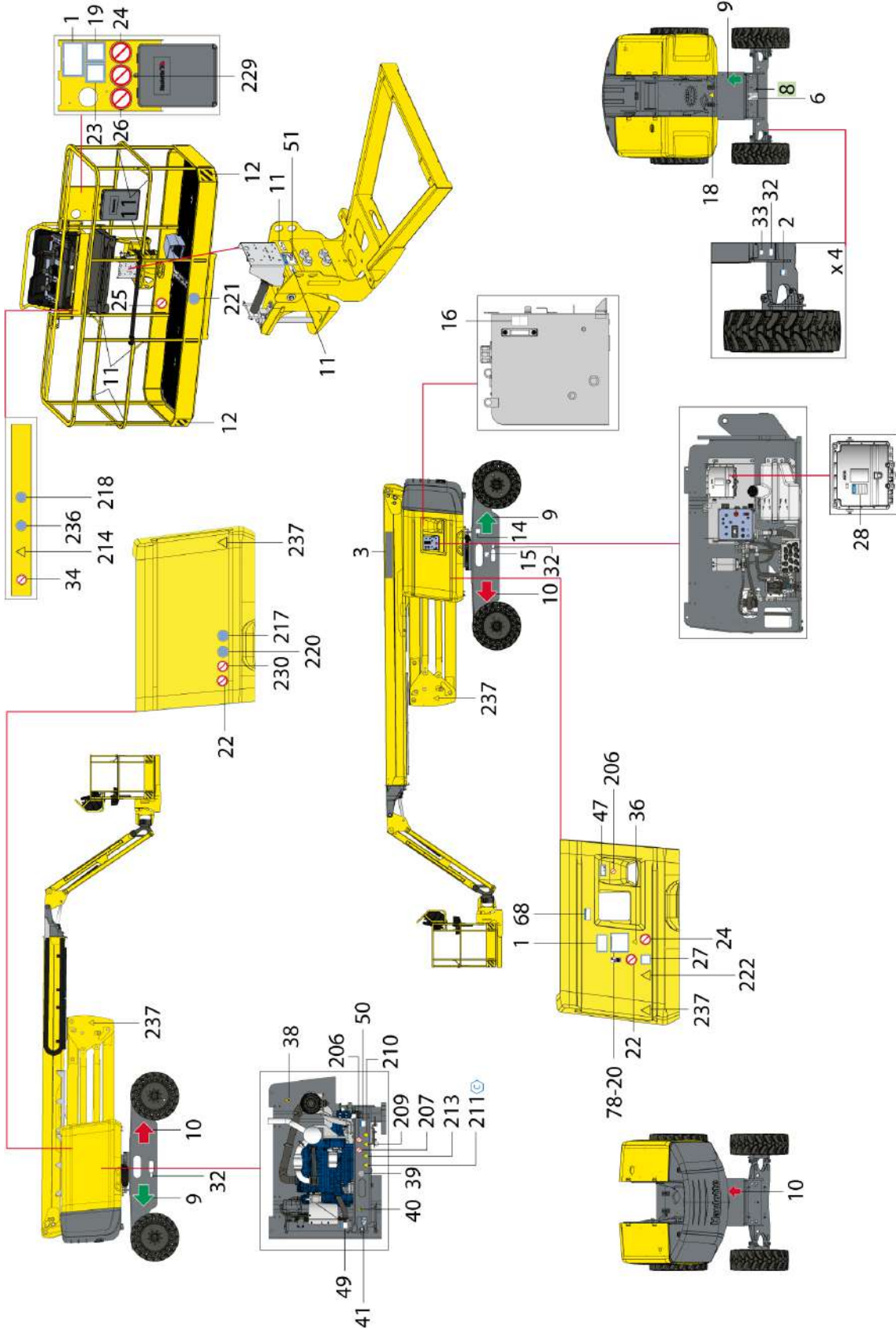

B - Familiarization

EAC standard - 4000359740 P

Marking	Color	Description	Quantity	HA20RTJ	HA20RTJO	HA20RTJ PRO
1	Red	Height of the floor and load	2	4000423800		
2	Blue	Maximum Pressure per Tire - Floor Loading	4	4000506620	4000359590	
3	Other	Commercial name-Bright machine	1	4000359400	4000359420	4000359440
3	Other	Commercial name-Dark machine	1	4000475740	4000475750	4000475760
6	Other	Identification plates	1	For Russia : 4000278870 For Ukraine : 307P227830		
8	Other	Noise emission level 101 Db	1	4000012860		
9	Other	Control of movements - GREEN directional arrow	3	3078143930		
10	Other	Control of movements - RED directional arrow	3	3078143940		
11	Other	Lanyard attachment points - Harness attachment compulsory	9	307P216290		
12	Other	Material risk - Yellow and black adhesive tape	4	4000421700		
14	Red	Risk of crushing - Spindle	1	307P227810		
15	Other	Crown greasing	1	307P227020		
16	Other	Max and min oil level	1	307P221060		
18	Orange	Hand crushing hazard - Risk of crushed hands	1	307P227660		
19	Other	Read the operation manual	1	For Russia : 307P227190 For Ukraine : 307P227840		
20	Red	Operation instructions	1	For Russia : 4000359920 For Ukraine : 4000359910		
22	Orange	Risk of crushing - Do not place foot	2	307P227010		
23	Red	Risk of crushing - Driving direction	1	307P227040		
24	Red	Danger of electrocution	2	307P226960		
25	Red	Risk of crushing - Closing drop rail	1	307P226950		
26	Red	Danger of electrocution - Platform - Ground for welding	1	307P226970		
27	Other	Tilt verification	1	For Russia : 307P227060 For Ukraine : 307P227870		
28	Other	Do not interchange	1	4000504670		
32	Blue	Towing anchorage point	6	4000135970		
33	Blue	Lifting anchorage point	4	4000135960		
34	Red	Electric Shock Hazards - Water projection	1	307P226780		
36	Red	Risk of crushing - Emergency lowering	1	4000014290		

B - Familiarization

Marking	Color	Description	Quantity	HA20RTJ	HA20RTJO	HA20RTJ PRO
38	Orange	Hand crushing hazard - Heat burns	1		4000200810	
39	Other	Oil CJ 4 (if fitted)	1		4000318680	
40	Orange	Hand crushing hazard - Snapping up	1		307P226940	
41	Yellow	Revolving cradle	1		307P215290	
47	Blue	Information - Explanation - LOW SULFUR - For Tier IV only	1	For Russia : 4000416640 For Ukraine : 4000416650		
49	Blue	Battery +	1		4000071960	
50	Blue	Battery -	1		4000071970	
51	Yellow	Socket - 240 V	1		4000027120	
68	Other	Transport height	1		4000417480	
78	Other	QR Code ( https://www.e.technical-information.com)	1		4001089310	
206	Other	Flames prohibited	2		307P226750	
207	Other	Smoking forbidden	1		307P226760	
209	Other	Battery danger	1		307P226790	
210	Other	Fire Hazard	1		307P226800	
211	Other	Electrical danger	1		307P226810	
213	Other	Corrosion hazard	1		307P226830	
214	Other	Danger unstable side	1		307P226930	
217	Other	Caution glasses	1		307P227460	
218	Blue	Caution helmet compulsory	1		307P226680	
220	Other	Hand protection compulsory	1		307P227490	
221	Other	Obligatory routing	1		307P227510	
222	Other	Danger unstable side	1		307P227680	
229	Other	Do not travel down slopes in high speed	1		307P226990	
230	Other	No admittance	1		307P227560	
236	Blue	Caution glasses	1		307P226670	
237	Yellow	Risk of crushing	4		307P227670	

B - Familiarization

ANSI and CSA standards - 4000424350 G - HA61RTJ O - HA61RTJ PRO

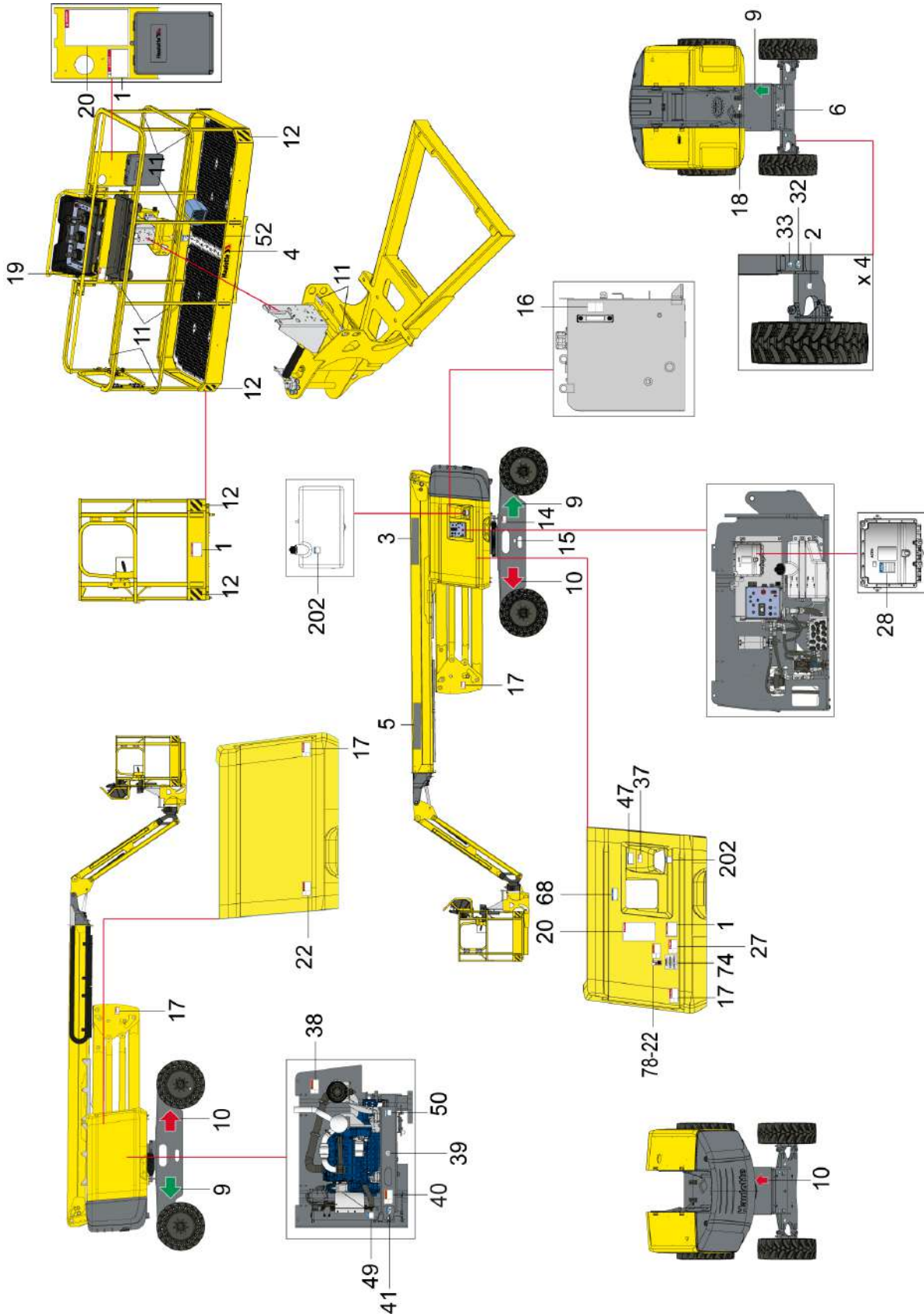

B - Familiarization

ANSI and CSA standards - 4000359740 P

Marking	Color	Description	Quantity	HA61RTJO	HA61RTJ PRO
1	Red	Height of the floor and load	3	4000701800	
2	Blue	Maximum Pressure per Tire - Floor Loading	4	4000359590	
3	Other	Commercial name	1	4000359460	4000359480
4	Other	500 x 100 Decal HAULOTTE®Bright machine	1	307P217080	
4	Other	500 x 100 Decal HAULOTTE®Dark machine	1	307P224740	
4	Other	500 x 100 Decal HAULOTTE®Red machine	1	307P220360	
5	Other	1860 x 280 Decal HAULOTTE®Bright machine	1	4000365570	
5	Other	1860 x 280 Decal HAULOTTE®Dark machine	1	4000390040	
5	Other	1860 x 280 Decal HAULOTTE®Red machine	1	4000390030	
6	Other	Identification plates	1	4000700170	
9	Other	Control of movements - GREEN directional arrow	3	3078143930	
10	Other	Control of movements - RED directional arrow	3	3078143940	
11	Other	Lanyard attachment points - Harness attachment compulsory	9	307P216290	
12	Other	Material risk - Yellow and black adhesive tape	4	4000421700	
14	Red	Risk of crushing - Spindle	1	In english : 4000024830 In french : 4000068080 In spanish : 4000086510	
15	Other	Crown greasing	1	4000025160	
16	Other	Max and min oil level	1	307P221060	
17	Red	Risk of crushing - Do not park	4	In english : 4000024640 In french : 4000067680 In spanish : 4000086460	
18	Orange	Hand crushing hazard - Risk of crushed hands	1	In english : 4000024770 In french : 4000067110 In spanish : 4000086490	
19	Other	Read the operation manual	1	4000025140	
20	Red	Operation instructions	2	In english : 4000027570 In french : 4000068880 In spanish : 4000086640	
22	Orange	Risk of crushing - Do not place foot	2	In english : 4000024840 In french : 4000068180 In spanish : 4000086610	
27	Other	Tilt verification	1	In english : 4000024860 In french : 4000068090 In spanish : 4000086520	

B - Familiarization

Marking	Color	Description	Quantity	HA61RTJO	HA61RTJ PRO
28	Other	Do not interchange	1	4000504670	
32	Blue	Towing anchorage point	6	4000027310	
33	Blue	Lifting anchorage point	4	4000027330	
37	Red	Explosion hazard	1	In english : 4000025010 In french : 4000068130 In spanish : 4000086560	
38	Orange	Hand crushing hazard - Heat burns	1	In english : 4000025040 In french : 4000068110 In spanish : 4000086540	
39	Blue	Engine oil - CJ-4	1	4000019700	
40	Orange	Hand crushing hazard - Snapping up	1	In english : 4000025020 In french : 4000068100 In spanish : 4000086530	
41	Yellow	Revolving cradle	1	3078151730	
47	Blue	Information - Explanation - LOW SULFUR - For Tier IV only	1	307P232480	
49	Blue	Battery +	1	4000071960	
50	Blue	Battery -	1	4000071970	
52	Blue	Socket - 110 V	1	4000027590	
68	Other	Transport height	1	4000417480	
74	Other	California warning - P65	1	4001026850	
78	Other	QR Code ( https://www.e.technical-information.com)	1	4001089310	
202	Other	Diesel Fuel Only	2	4000201430	

C - Pre-operation inspection

1 - Recommendations

The owner, the site manager, the supervisor and the operator are all responsible to ensure the machine is fit for the work it is to perform; i.e. that the machine is suitable to carry out the work in complete safety and in compliance with this Operator's Manual. All managers who are responsible for persons operating the machine must be familiar with the local regulations currently applicable in the country of use and ensure that they are adhered to.

Before using the machine, read the previous chapters in this manual. Ensure that you have understood the following points :

- Safety precautions.
- Operator's responsibilities.
- Conditions and the operating principles of the machine.

2 - Working area assessment

Before any operation :

- Carry out a thorough inspection of the site to identify any potential risks within the work zone.
- Take the necessary precautions to avoid collisions with other machinery within the work zone.

Ensure that :

- The weather conditions (wind, rain, etc.) allowing the machine to be used.
- The ground withstands the weight of the machine and has not been affected by the poor weather conditions.
- Check that the authorisations to work with the machine on the site in question have been obtained (.g. chemical product factories).
- Define a rescue plan for all the risks, including the risk of falls and crushing.

C - Pre-operation inspection

3 - Inspection and Functional test

3.1 - DAILY INSPECTION

Each day before the beginning of a new work session and with each change of operator, the machine must be subjected to a visual inspection and a complete functional test.



- Never use a defective or a malfunctioning aerial work platform.
- If any item on the check list is marked "No" during the inspection; machine must be tagged and placed out of service.
- Do not operate the machine until all identified items are corrected and it has been declared safe for operation.

In case of loose fasteners, refer to torque table value in maintenance book.

In case of leaks, replace the damaged part before use.

In case of structural part deformation (cracks, broken weld, paint chips) replace the part before use.



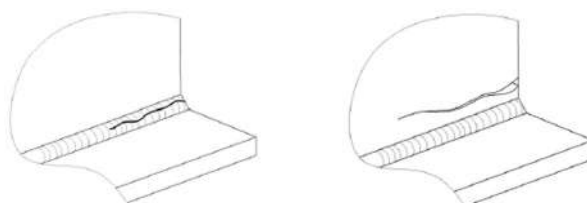





Sample of broken welds



We recommend these forms to be completed daily and stored to assist with your maintenance schedule.

Each action is depicted in the daily inspection sheet using the following symbols.















Use the detailed program below.

	Oil change		Lubrication-Lubrication		Tightening
	Levelling		Systematic replacement		Functional adjustments / Checks / Cleaning
	Visual inspection		To check by test		

Serial number : Hours of operation : HAULOTTE Services® contract reference : Intervention record number : Date : Name :	Model : Signature :
--	--



















C - Pre-operation inspection

Articulated and telescopic fuel-powered aerial work platforms

	Page or associated procedure	Daily	OK	NOK	Corrected	Comments
Chassis assembly : Wheel, reducer, steering, wheel pivot						
Check state of tires/tyres and inflations						
Thermal engines						
Check engine fuel level (Top up the oil if necessary)						
Check engine oil level (Top up the oil if necessary)						
No leaks from engine components (engine, hoses, radiator)						
Check the condition of the battery						
Check the cooling circuit level (Top up the oil if necessary)						
Check the condition of the circuit LPG (If equipped)						
Check the operation of the lock on the engine casing						
Turntable						
Test the operation of the turntable locking system						
Hydraulic : oils, filters and hoses						
Check the hydraulic oil level (Top up the oil if necessary ; Machine stowed)						
Check the clogging indicator on the hydraulic pressure filter (change if clogged)						
Check the hoses, blocks and pumps, fittings, cylinders and the tank for the absence of leaks, deformations and damage						
Platform						
Ensure that the gate or sliding bar shall be designed to either return automatically to the closed and latched position						
Check that the harness anchor points are not cracked or damaged						

C - Pre-operation inspection

Articulated and telescopic fuel-powered aerial work platforms

	Page or associated procedure	Daily	OK	NOK	Corrected	Comments
General						
Check for the presence, cleanliness and readability of the manufacturer's plates, security labels, user manual and maintenance manual						
Check the cleanliness and readability of the control box						
Test the opening and closure of covers (chassis, turntable, upper control box)						
Check the condition of electrical harnesses, cables and connectors						
Check for the absence of abnormal noise and jerky movements						
Check for the absence of visible deterioration and damage						
Check for the absence of cracks, broken welds and chipped paintwork on the structure						
Check for the absence of missing or loose screws and bolts						
Check for the absence of deformation, cracking and breakage of axis stops, bushing and axes						
Check for the absence of foreign bodies in joints and sliding parts						
Safety devices						
Test the operation of the upper and lower control boxes: manipulators, switches, buttons, horn, emergency stops, screens and lights						
Test the operation of visual and audible alarms						
Test the operation of the tilt system						
Test the operation of the emergency lowering system						
Test the operation of the axle locking system						
Test the operation of the loading control system (visual alarm on the control box)						
Test the operation of the Activ Shield Bar (if equipped)						

C - Pre-operation inspection

4 - Safety functional checks

To protect the user and the machine, safety systems prevent the movement of the machine beyond its operating limits. These safety systems when activated immobilize the machine and prevent further movement.

The operator must be familiar with this technology and understand that is not a malfunction but an indication that the machine has reached an operation limit.

Aerial Work platforms are equipped with two control boxes which allow operators to safely use the machine. An auxiliary system (Overriding system) is available on the ground control box in order to rescue anyone trapped on the platform.

The following checks describe the operation of the machine and the specific controls required.

For the location and description of these controls :  refer to section B 3.2 and D 2 - Ground control box and B 3.3 and D 3 - Platform control box.

4.1 - E-STOP BUTTON CHECK

Ground control box E-stop button

Step	Action
1	Pull the E-Stop button (9) at the ground control box.
2	Set the key switch (22) at ground box to the  position
3	The indicator (10) lights up on ground control box
4	Start the engine by pressing the engine start-up selector (16) .
5	Push in the E-stop button (9) .
6	Check that the engine stops running.
7	Check no movements are functional.

Platform control box E-stop button

Step	Action
1	Pull the E-Stop button (9) at the ground control box.
2	Set the key switch (22) at ground box to the  position
3	Pull out the E-Stop button (46) at platform box.
4	The indicator (13) lights up on ground display panel
5	Start the engine from platform using Start/Stop switch (230) .
6	Push in E-Stop button (46) at platform.
7	Check that the engine stops running.
8	Check no movements are functional.

C - Pre-operation inspection

4.2 - ACTIVATION OF CONTROLS

The enable foot pedal (enable switch) must be activated to allow any movement.

The "Enable Switch" system depends on the machine configuration and will consist of one of the following :

- Joystick trigger at platform box (if fitted).
- Foot pedal (enable switch) in the platform (Optional).
- Enable switch at ground box.

4.3 - FAULT DETECTOR

The machine is equipped with an on-board fault detection system, which indicates the type of fault to the operator.

The fault is identified by a default code.

The default code is displayed at the ground control box.

According to the type of fault, the machine MAY switch into DOWNGRADEMODE mode and certain movements are prevented to maintain Operator's safety.

Do not use the machine until the fault has been corrected.

4.3.1 - Indicators/LED's test

From the ground control box

Step	Action
1	Pull the E-Stop button (46) at the platform control box.
2	Set the key switch (22) at ground box to the  position
3	Check that the LEDs (10, 13, 15, 19) light up on ignition and that the display is also lit up

From the platform control box

Step	Action
1	Pull E-Stop button (9) at ground box.
2	Set the key switch (22) at ground box to the  position
3	First push in the E-Stop button (46) at platform box, then pull out.
4	Check that the indicators (101 - 117) on the platform control box flash upon start-up.

4.3.2 - Buzzers test

From the ground control box

Step	Action
1	Pull both E-Stop buttons (9) at ground box and (46) at platform box.
2	Set the key switch (22) at ground box to the  position.
3	The buzzers on the ground and platform beep upon start-up.

C - Pre-operation inspection

4.4 - AUTOMATIC ENGINE CUT-OUT

The engine automatically cuts out in the following conditions :

- The alternator is not functioning.
- Engine temperature is too high.
- Oil pressure is too low.
- The E-stop(s) is (are) pushed in.
- The machine is switched off.

4.5 - OVERLOAD SENSING SYSTEM

If the platform load exceeds the maximum allowed load, no movement is possible from the 2 control boxes.

At ground and platform control boxes a buzzer sounds and an indicator light warns the operator.

To return the machine to normal operation remove weight from the platform until the load is below the maximum allowed load.

Daily check that the LED's illuminate when the machine is switched on :

- Verify that the Overload system is active : Refer to Indicator (15) at ground control box and LED (114) at platform control box display.
- Verify that the buzzers are functioning : Refer to Buzzers test.

A periodic inspection of this device must be performed according to the recommendation in Maintenance Schedule.

4.6 - OSCILLATING AXLES (IF EQUIPPED)

To improve the driving capability on rough terrain, the front axle is equipped with an oscillating mechanism. When the extending structure is retracted and is in the stowed position, oscillating mechanism is unlocked to adapt itself to the features of ground operation. When the extending structure is out of the stowed position, a safety device locks the oscillating mechanism to reduce overturning hazard.

A visual inspection must be performed to ensure the absence of leaks from the oscillating cylinder and associated plumbing connections including the hydraulic hoses.

A periodic inspection of this device must be conducted according to the recommendation in the maintenance schedule.

A

B

C

D

E

F

G

H

I

C - Pre-operation inspection

4.7 - SLOPE WARNING DEVICE

From each control box, a buzzer alerts the operator that the machine is not folded/stowed and is positioned on a slope exceeding the slope allowed.

N.B.-:-THE SLOPE SENSOR IS ONLY ACTIVE WHEN THE PLATFORM IS NOT IN THE STOWED POSITION.

When machine is on a slope greater than the rated slope, with extending structure out of the stowed position :

- The DRIVE and LIFTING (RAISING) commands are deactivated.

The lowering speeds are reduced.

In this case, fully lower the platform and reposition the machine on level ground before raising the platform again.

To check the tilt sensor at ground level, perform the following steps :

To check the tilt sensor at ground level

Step	Action
1	Open the right hand compartment cover (Component location diagrams) and locate the tilt sensor (C28). Tilt sensor is located on the base plate of turret on the right hand side of the ground control box.
2	Pull out both E-Stop buttons (9) at ground box and (46) at platform box.
3	Set the key switch (22) at ground box to the  position
4	Start the engine by pressing the engine start-up selector (16) .
5	Manually tilt the sensor (C28) and hold.
6	Check that the audible beep sounds.

C - Pre-operation inspection

4.8 - TRAVEL SPEED LIMITATION

The machine has a selector of 3 driving speeds - low, medium and high.

All driving speeds are authorised when extending structure of the machine is in stowed position (transport configuration). Drive speed is proportional to the movement of the drive joystick (33). Adjust position of Jib to enhance field of vision during driving.

Whatever the position of the drive speed selector switch (45) on the platform control box, the drive speed is limited when the machine is unfolded.

Daily check that the speed is limited to less than 1 km/h (0.6 mph) when :

- The boom is raised by more than 10° above horizontal.
- The boom is telescoped/extended more than 400 mm (16 in).
- The arm is raised by more than 2 m (6 ft 7 in) above horizontal.

4.9 - ON-BOARD ELECTRONICS

The machine is equipped with a specific calculator configured for this machine's functionalities. Do not interchange the Calculator (calibration restoration) between machines..

A

B

C

D

E

F

G

H

I

D - Operation instructions

1 - Operation

1.1 - INTRODUCTION

Only trained and authorized personnel shall be permitted to operate this aerial work platform.

Prior to operation :



- Read, understand and obey all instructions and safety precautions in this manual and attached to the aerial work platform.
- Read, understand and obey all local regulations.
- Become familiar with the proper use of all controls and emergency systems.

1.2 - MAJOR DESCRIPTION

All the machines are equipped with :

- Platform control box.
- Ground control box (Auxiliary power and overriding system).
- Stop Emission System.

1.3 - OPERATION FROM THE GROUND CONTROL BOX

- Turning "ON" and "OFF" of the machine is performed with the Control box activation key switch (22).
- Activation of a desired control box is achieved by turning the Control box activation key switch (22) to the desired position .
- The ground control box is energized and is active ONLY when :
 - The E-stop buttons on both ground and platform control boxes are not pressed in (Deactivated).
 - To switch ON the machine, turn the Control box activation key switch (22) at the ground control box on ground control box position .
- An E-Stop button at each control box stops all movements when pressed in; including shutting off an engine (if equipped).



N.B.-:-DO NOT TURN OFF THE POWER SUPPLY OF THE MACHINE USING THE E-STOP BUTTON(USE ONLY IN CASE OF EMERGENCY). TURN OFF THE POWER SUPPLY OF THE MACHINE USING THE

CONTROL BOX ACTIVATION KEY SWITCH 22 TO  POSITION.

D - Operation instructions

- An Enable /Foot Switch (6) is present that should be activated and maintained to authorize one or more movements. If Enable Switch (6) is kept engaged without selecting a function movement for more than 8 seconds ; Enable Switch is automatically de-activated.
- Only movements to lift, lower and rotate the platform are possible from the ground control box.
- All controls operating a movement, return automatically to neutral when released.
- At power up, all controls must be in their neutral position (not activated).
- Enable Switch / Back-up unit selector (6) :
 - With engine running, the selector (6) functions as an Enable Switch only.
 - With engine stopped, the selector (6) functions as the Enable Switch and activates the back-up unit (emergency pump).
- Overriding system : The ground control box is an auxiliary control box to use in emergencies only. Refer to  Section D 4.2 - To rescue operator in platform.
- The status of the controls is tested automatically when the machine is switched on.
- Pressing engine start-up selector (16) starts or stops the engine.
- A buzzer beeps in the following conditions :
 - When power is switched on.
 - Overload.
 - Slope if machine is out of stowed position.
 - Hydraulic oil overheating.
 - Movement buzzer option.
 - Drive buzzer option.
- Indicators (10), (13), (15) and (19) are checked when the machine is powered on.

For petrol / gas machines :

- For desired type of fuel; activate button (18)  for petrol or (17)  for propane gas.

D - Operation instructions

1.4 - OPERATION FROM THE PLATFORM CONTROL BOX

- The platform control box is energized only when :
 - The E-stop buttons on both ground and platform control boxes are not pressed in.
 - To switch ON the machine, turn the Control box activation key switch (22) at the ground control box to platform control box position .

- Overriding system not activated.
- A faulty joystick is not taken into account to control a movement. If this fault disappears, the movement is authorised again.
- An E-Stop button at each control box stops all movements when pressed in; including shutting off an engine (if equipped).

N.B.-:-DO NOT TURN OFF THE POWER SUPPLY OF THE MACHINE USING THE E-STOP BUTTON(USE ONLY IN CASE OF EMERGENCY). TURN OFF THE POWER SUPPLY OF THE MACHINE USING THE

CONTROL BOX ACTIVATION KEY SWITCH (22) TO  POSITION.

- A Foot Switch (C42) is present and should be activated and maintained to authorize one or more movements. If Foot Switch is kept engaged without selecting a function movement for more than 8 s seconds ; Enable switch is automatically de-activated.

N.B.-:-IT IS RECOMMENDED THAT OPERATOR REMOVES THE FOOT FROM THE FOOT SWITCH WHENEVER A MOVEMENT HAS CEASED.

- The release of 'Enable switch' foot pedal while performing a movement stops that function movement and all other movements are inactive. The stop of movements is progressive. If the Foot Switch is pressed again quickly within 0,5 s the movement restarts. If the Foot Switch and / or Enable Switch is not pressed again quickly enough within + 0,5 s the movement will not restart. It could restart only when the selected function switch/joystick is released to neutral position.
- All switches and joystick operating a movement, return automatically to neutral when released.
- At power up, all switches and joysticks must be in their neutral position.
- For petrol / gas machines : The fuel selection (petrol or liquid propane gas) is done by turning the switch (44) to the desired position.
- The status of the switches is tested automatically when the machine is switched on and checked at every starting. A switch will be activated only after it has been detected in neutral position.
- Emergency pump. ( Section D 4.1 - In case of engine power failure)

D - Operation instructions

- Indicators - All indicators (LEDs 101 - 117) are checked when the machine is powered on
- A buzzer beeps in the following conditions :
 - When power is switched on.
 - Overload.
 - Machine elevated on a slope greater than the rated slope.



While driving on a slope :

- **While driving, always place the boom above the rear axle, in the direction of movement.**
- **Always orientate the machine in the direction of the slope.**
- **Always place the boom in fully retracted and in stowed position.**
- **Do not travel down slopes in high speed.**
- **Do not drive fast in narrow or cluttered areas. Keep speed under control while making turns or sharp bends.**

D - Operation instructions

2 - Ground control box

2.1 - TO START AND STOP THE MACHINE - DIESEL ENGINE

- Check that the E-stop buttons (9) at ground control box and (46) at platform control box are not pressed in.

- Turn the control box selector (22) to position  to energize the ground control box.

- Press the starter selector (16) to start the engine.

- Let the engine heat up.

To shut-down the machine from the ground control box :

- Press the starter selector (16) to stop the engine.

- Turn the activation selector key switch (22) to off position .

- Power supply is now switched off.

N.B.-:THIS OPERATION TURNS OFF THE POWER SUPPLY TO MACHINE AND IT IS REQUIRED TO PREVENT BATTERY DISCHARGE.

N.B.-:THE DISPLAY AUTOMATICALLY GOES INTO STANDBY IF NOT USED FOR AN EXTENDED PERIOD. TO SWITCH IT ON AGAIN, TURN THE KEY SELECTOR TO THE OFF POSITION THEN FOLLOW THE START-UP PROCEDURE.

2.2 - TO START AND STOP THE MACHINE - PETROL / GAS (PROPANE) ENGINE

- Open the gas bottle valve (C140).

- At the ground control box, check that the E-stop button (9) is not pressed in.

- Turn the control box selector (22) to position  to energize the ground control box.

- Press the propane gas control (17) for liquid gasoline supply.

- Press the starter selector (16) to start the engine.

- Let the engine heat up.

D - Operation instructions

To shut-down the machine from the ground control box :

- Press the starter selector (16) to stop the engine.
- Turn the activation selector key switch (22) to off position 
- Power supply is now switched off.
- Close the gas bottle valve (C140).

N.B.-:-THIS OPERATION TURNS OFF THE POWER SUPPLY TO MACHINE AND IT IS REQUIRED TO PREVENT BATTERY DISCHARGE.



If the gas bottle is empty, the engine stops. Press switch (18) for gasoline supply. Restart the engine.











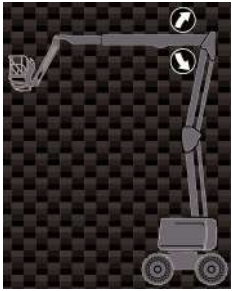

N.B.-:-THE DISPLAY AUTOMATICALLY GOES INTO STANDBY IF NOT USED FOR AN EXTENDED PERIOD. TO SWITCH IT ON AGAIN, TURN THE KEY SELECTOR TO THE OFF POSITION THEN FOLLOW THE START-UP PROCEDURE.

D - Operation instructions





2.3 - MOVEMENT CONTROL

N.B.-:-RELEASING THE ENABLE SWITCH (6) WILL STOP ALL MOVEMENTS.

Ground box controls (emergency station)

Command		Action
Raising / lowering of boom		Press the boom raising control (4) to raise  the boom.
		Press the boom lowering control (4) to lower  the boom.
Raising / lowering of arm		Press the arm raising control (5) upwards  to raise the arm
		Press the arm lowering control (5) downwards  to lower the arm
Boom telescoping extend / retract		Press the boom telescoping control (3) to extend  the boom.
		Press the boom retracting control (3) to retract  the boom.
Jib raising / lowering (If applicable)		Press the jib raising control (2) to raise  the jib.
		Press the jib lowering control (2) to lower  the jib.

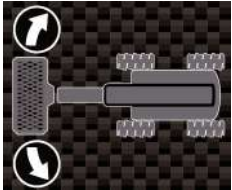
D - Operation instructions

Command		Action
Turntable rotation		Press the turntable rotation control (7) for a clockwise rotation 
		Press the turntable rotation control (7) for a counterclockwise rotation 
Platform rotation		Press the platform rotation control (8) for a clockwise rotation 
		Press the platform rotation control (8) for a counterclockwise rotation 

D - Operation instructions

3 - Platform control box

3.1 - TO START AND STOP THE MACHINE

3.1.1 - To start the machine

At the ground control box :

- Check that the E-stop button (9) is not pressed in.
- Turn the control box activation key switch (22) to platform position  to energize platform control box.

At the platform control box :

- Check that the E-Stop button (46) on platform control box is not pressed in.
- Push the starter selector switch (230) upwards. During pre-heating, the indicator (102) comes ON on the display panel of the platform control box. Pre-heating begins and the engine starts.
- Allow the engine to heat up and initialize.

3.1.2 - To stop the engine

- Press the engine starter selector (230) and the engine stops.

3.1.3 - If engine is stopped by Stop Emission System

- The Stop Emission System automatically stops the engine after 90 s of inactivity.
- Press the foot switch (C42) to restart the engine.

N.B.-:IF THE FOOT SWITCH IS STILL ENGAGED, RELEASE AND PRESS AGAIN.



The display automatically goes into standby if not used for an extended period. To switch the display on again, press the emergency stop button then follow the start-up procedure. .

D - Operation instructions

3.2 - TO START AND STOP THE MACHINE - PETROL / GAS (PROPANE) ENGINE

To start the machine :

At the ground control box :

- Open the gas bottle valve.
- Check that the E-stop button (9) is not pressed in.
- Turn the control box key selector (22) on position  to energize the machine and activate the platform control box

At the platform control box :

- Open the gas bottle valve.
- Check that the E-stop button (46) is not pressed in.
- Turn the petrol/liquid propane gas selector (44) into LPG position
- Push the starter selector switch (230) upwards. During pre-heating LED (102) at platform display panel and LED (5) at ground display panel will light up. Pre-heating begins and the engine starts.
- Allow the engine to heat up and initialize.

To stop the engine :

- Push engine start switch (230) upwards.
- Close the gas bottle valve



If the gas bottle is empty, the engine stops. Turn the petrol/liquid propane gas selector (44) into G position. Restart the engine.



The display automatically goes into standby if not used for an extended period. To switch the display on again, press the emergency stop button then follow the start-up procedure. .







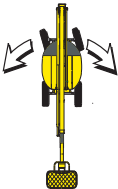

D - Operation instructions

3.3 - DRIVE AND STEER CONTROL

N.B.-:-RELEASING THE ENABLE SWITCH (6) WILL STOP ALL MOVEMENTS.

Before driving, locate the green / red orientation arrows on the chassis. These will determine the direction in which the machine is traveling.

Move the drive control joystick (33) in the direction matching the directional arrows.

Command		Action
Steering		Press thumb/rocker switch on joystick (33) to the right to steer right.
		Press thumb/rocker switch on joystick (33) to the left to steer left.
Steering mode selection		Synchronised axle : 4 wheel steering mode
		2 front steering wheels from axle
		Crab mode axle
Driving		Move joystick (33) forwards for the machine to travel in the forward direction.
		Pull joystick (33) backwards for the machine to travel in the reverse direction.
Drive speed		Position the drive speed selector switch (45) on  for high-speed driving.
		Position the driving speed selector (45) on  for low-speed driving (short distance, final approach, unloading from lorries/trucks).

N.B.-:-STEERING MODE OPERATES BY OIL TRANSFER. TO REALIGN THE REAR AXLE, IT MAY BE NECESSARY TO SWITCH BACK TO 2 WHEEL DRIVE FIRST.

D - Operation instructions

3.4 - MOVEMENT CONTROL

N.B.:-RELEASING THE ENABLE SWITCH (C42) WILL STOP ALL MOVEMENTS.

Foot Switch

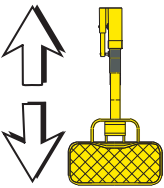
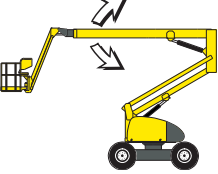
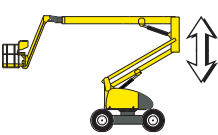
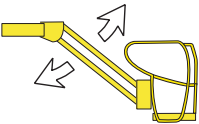

Command		Action
Boom telescoping extend / retract		<p>Push the boom telescoping switch (54) upwards to retract the boom.</p> <hr/> <p>Push the boom telescoping switch (54) downwards to extend the boom.</p>
Boom raising / lowering		<p>Move the boom/turntable joystick (49) forward to raise the boom.</p> <hr/> <p>Move the boom/turntable joystick (49) backwards to lower the boom.</p>
Arm raising / lowering		<p>Push the arm joystick (50) forwards to raise the arm.</p> <hr/> <p>Push the arm joystick (50) backwards to lower the arm.</p>
Jib raising / lowering		<p>Push the jib switch (129) upwards to raise the jib.</p> <hr/> <p>Push the jib switch (129) downwards to lower the jib.</p>

D - Operation instructions

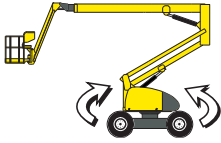
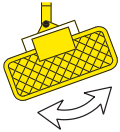
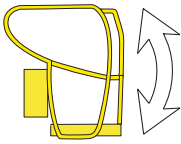
Command		Action
Turntable rotation		<p>Move the boom/turntable joystick (49) to the left for a clockwise (CW) rotation.</p> <p>Move the boom/turntable joystick (49) to the right for a counter clockwise (CCW) rotation.</p>
Platform rotation		<p>Move the platform rotation switch (38) to the right for a counter clockwise (CCW) rotation.</p> <p>Move the platform rotation switch (38) to the left for a clockwise (CW) rotation.</p>
Platform leveling		<p>Move the platform levelling switch (40) upwards to raise the platform to the front of the machine.</p> <p>Move the platform levelling switch (40) downwards to tilt the platform to the rear of the machine.</p>

3.5 - ADDITIONAL CONTROLS

- Horn : Push the horn selector (43) to the right to sound the horn. The horn stops when the selector switch is released.

D - Operation instructions

4 - Rescue and emergency procedures

4.1 - IN CASE OF POWER LOSS

In case of loss of the main power source, the secondary (back-up) power unit, powered by the starting battery, allows movements to be controlled from both the ground and platform control boxes.

As the electric pump has limited power, it is advisable to reach the ground in the most direct manner possible.

The use of the electric pump is exclusively reserved for lowering the boom in emergency situations only. You are advised to retract the telescope before lowering the boom.

N.B.-:TEST THE OPERATION OF EMERGENCY SYSTEM ATLEAST ONCE A MONTH. REFER TO THE SERVICE MANUAL.

Depending on the control box in use, push and hold the back-up/auxiliary power switch (6) at ground box or switch (41) at platform box. Retract the boom and lower it by using switches (3) and (4) at ground box or switch (54) and joystick (49) at platform box.

In an emergency, if the operator has to exit the platform while it is elevated, the transfer of the operator must respect the following recommendations. :

- Exit onto a sturdy and safe structure.
- Allowance must be made for the possibility of boom deflection when egressing from the platform.
- The occupant(s) must ensure that 2 lanyards are used for security/safety. One must be attached to the designated anchorage point on platform the occupant(s) is in and the other attached to the structure intended to get on.
- Do not leave platform without taking into account the allowance for possibility of boom deflection when exiting platform.
- Occupant(s) must exit the current platform through the normal access.

N.B.-:DO NOT DETACH THE LANYARD FROM THE CURRENT PLATFORM IF THE TRANSFER TO THE NEW STRUCTURE POSES ANY DANGER OR UNTIL THE TRANSFER IS SAFELY COMPLETED. DO NOT ATTEMPT TO CLIMB DOWN THE BOOM. INSTEAD WAIT FOR ASSISTANCE FOR A SAFE EXIT.

D - Operation instructions

4.2 - TO RESCUE OPERATOR IN PLATFORM



In a situation where an operator located in the platform needs to be rescued (for example in case of illness, injury or trapped against a structure making the control box inaccessible), the rescue personnel at ground level needs to obtain rapid and direct access to operating functions.

HAULOTTE® has implemented a control system for safely lowering the operator to the ground in the event of an emergency to enable him to receive the necessary treatment.



The system allows occupant(s) to be lowered to the ground level, even if an E-Stop is engaged or if an overload is detected.

Procedure :

- Turn the ground control box key control (22) to the ground control box  position.
- The platform box controls are now de-energized.
- Check that the E-Stop button (9) at ground is not pressed in.
- To lower the platform, hold down the Enable Switch (6)  and simultaneously activate the desired control function.







4.2.1 - Operation of overriding system from ground control box

N.B.-:IF THE SAFETY SYSTEMS DO NOT ALLOW NORMAL MOVEMENT FROM THE GROUND CONTROL BOX, OR IN THE EVENT OF OVERHEATING, USE THE OVERRIDING SYSTEM DESCRIBED BELOW.



Operation of the "overriding system" switch must be an exception and not a normal emergency operation.

Procedure :

- Press and hold the "overriding" system control (11) .
- Press simultaneously the telescoping boom control (3) to retract the boom .
- Press the boom raising control (4) to raise  or lower  the boom.
- Press the arm raising control (5) to raise  or lower  the arm.

N.B.-:ONCE RESCUE OPERATIONS ARE COMPLETE, WRITE AN INCIDENT REPORT.

D - Operation instructions

4.3 - NO POWER AVAILABLE

In case of loss of the main power and the secondary power unit not functioning, do not attempt to activate any function movement using hydraulic manifold unless trained and authorized by HAULOTTE Services®. All safety functions are no longer active and several hazards may occur. Improper use of the equipment will result in death or serious injuries.



If the operator cannot be lowered by any of the above mentioned methods, contact HAULOTTE Services® immediately.

D - Operation instructions

5 - Transportation

5.1 - TRANSPORT CONFIGURATION



During loading, ensure that :

- The loading ramp can support the machine weight.
- The loading ramp is correctly attached to transport vehicle.
- The loading ramp has sufficient grip surface.
- The transport vehicle must be parked on a level surface and must be secured to prevent rolling away while machine is being loaded or unloaded.

Do not place yourself below or too close to the machine during loading.

The machine must be completely in the stowed configuration :

- Check the platform is completely empty.

To climb the slope, select low driving speed.

If the slope is too steep, use a winch in addition to the low speed drive.

- Raise the jib to maintain ground clearance when driving the machine onto a loading ramp.
- Lower the boom.
- Ensure that the jib is raised as necessary to give ground clearance when driving the machine onto the loading ramp.
- Drive onto the truck bed slowly.
- Secure the machine to the tie down points provided (Section D-Machine layout).
- Lock the turntable with the rotation stop pin located under the turntable before transporting (Section D-Machine layout).
- The platform/basket must be chocked and the boom strapped to prevent bouncing up and down, thus preventing possible material damage during transporting.
- Do not use excessive downward force when securing boom section.



A wrong move can lead to machine tipping over and may cause serious injuries and material damage.



Always align the boom in the axis of the machine and climb slopes with the platform lowered and on the downhill side of the machine.



To enter or exit from the platform : Falling Hazards ( Section A 2.1.2).

D - Operation instructions

5.2 - MACHINE STOWAGE FOR TRANSPORT - HA20RTJ - HA20RTJ O - HA20RTJ PRO - HA61RTJ O - HA61RTJ PRO

Turntable rotation enabled



Turntable rotation disabled



D - Operation instructions

Machine stowing

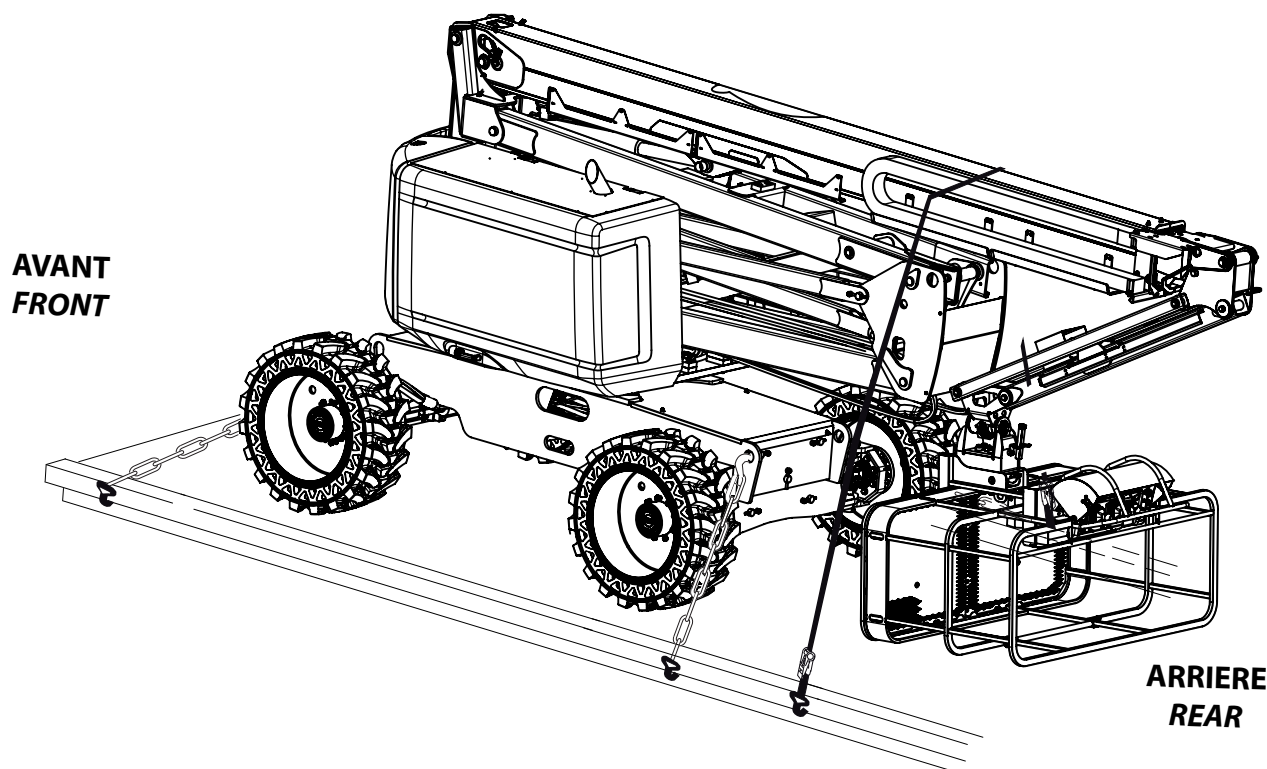

N.B.:-SECURE TURNTABLE WITH THE TURNTABLE LOCKING PIN BEFORE TRAVELING LONG DISTANCES OR HAULING MACHINE ON A TRUCK.

5.3 - UNLOADING

Before unloading, check that the machine is in good condition.

- Remove the turntable rotation locking pin (Section D-Machine layout).
- Remove the tie downs.
- Select low drive speed at the platform control box.
- Start the machine from platform control box.



Warning : Upon starting a machine that has been secured and transported, the safety system may detect a false overload preventing all movement from the platform control box.

To reinstate the system, lift the jib a few centimetres (inches) using the ground control box.

D - Operation instructions

5.4 - TOWING



In the event of a machine breakdown, the machine can be towed a short distance to load it onto a transport vehicle :

- Ensure that no one is in the platform during towing.
- Ensure boom is in the stowed position and the turntable is locked, prior to towing.
- The platform must be empty.

To tow a broken-down machine, disconnect the wheel drive hubs.

Perform this operation on flat ground with wheels chocked.

In the towing configuration, the machine braking system is inactive. Use a drawbar to avoid any risk of accident :

- Do not exceed the maximum speed (machine unfolded) (Refer to  Section B 4.1 - Technical specifications).



To go up or down a slope, use the appropriate winch.

5.4.1 - Disengaging the drive hubs

- Use an 11 spanner to undo and remove the 2 screws from the plate.



D - Operation instructions

- Remove the plate, turn it over and install it in place with the 2 screws removed previously.

N.B.-:THE PLATE BOSS WILL PUSH THE SPRING IN. THE DRIVE HUBS ARE NOW DISENGAGED.



When drive hubs are disengaged, the machine is in free wheel mode and the brake system no longer functions.

5.4.2 - Re-engaging the drive hubs

- To return machine to normal operation and braking, reverse the steps performed in disengaging the drive hubs.



Carry out a few driving movements. The drive hubs are now re-engaged.

Machine is now in the normal driving mode.

A

B

C

D

E

F

G

H

I

D - Operation instructions

5.5 - STORAGE



The machine can be stored in a designated area when not in use. If it is stored for more than 3 months without being used, an inspection must be carried out before it is put back into service.



For engine storage condition follow engine supplier operator and maintenance manuals.

Machine must be parked in a protected/designated area with the boom in a stowed configuration, however the boom can be raised but must not be extended. Make sure there is no load in the platform.

Do not store or immobilise the machine when it is unfolded.

Ensure all access panels, doors and side compartment covers are shut and secured.

Turn the control box activation key switch (22) at the ground control box to the extreme

left  to shut OFF the power.

Ensure that the turntable rotation locking pin is removed and stored properly.

Remove the ignition key to prevent unauthorized operation of the machine.



Storing of the machine with an obstacle under the boom structure is forbidden.



To avoid any risk of corrosion on rods of cylinders during a storage period of more than 1 month :

- In a normal atmospheric environment : perform a complete cycle for the cylinders every 2 months while they are in storage.
- In harsh environments (high levels of salinity in the atmosphere: close to the sea, industrial environment with chloride emissions and/or humidity >70%), we recommend applying the following protection process :
 - Wash and rinse the entire machine with plenty of clean water.
 - Dry all the cylinder rods using an air gun.
 - Apply a solvent-based oil leaving an oily film after evaporation of the solvent directly to all rods left exposed when the machine is in storage position.
 - Re-apply the product every month.



After washing the machine, make sure it is fully air-dry and does not contain moisture on corrosive parts (cylinders rods for example).

Do not wash any electrical components, particularly with high pressure washer. Wipe away dirt from around electrical components with a dry cloth.

D - Operation instructions

5.6 - LIFTING OPERATION

During loading / unloading operation with an overhead crane, it is important to respect the following :

- Put the machine in stowed position, boom and arm fully retracted and lowered.
- Platform must be empty.
- Rotate the turret and the jib to the configuration in the photos below.
- Lock the turret with turret locking pin.
- Verify that lifting attachments are in good operating condition and match the technical specifications. Lifting devices must be attached only to the designated lifting eyes.
- Each of the slings used for lifting the machine must be adjusted to keep the machine level and to minimize the risk of damage to the machine.

- Anchorage point for lifting are identified / labeled by the following symbol .
- ONLY trained and authorized personnel should attempt to lift the machine.



Never lift the machine with slings attached to counterweight.

A

B

C

D

E

F

G

H

I

D - Operation instructions

Procedure for the use of slings

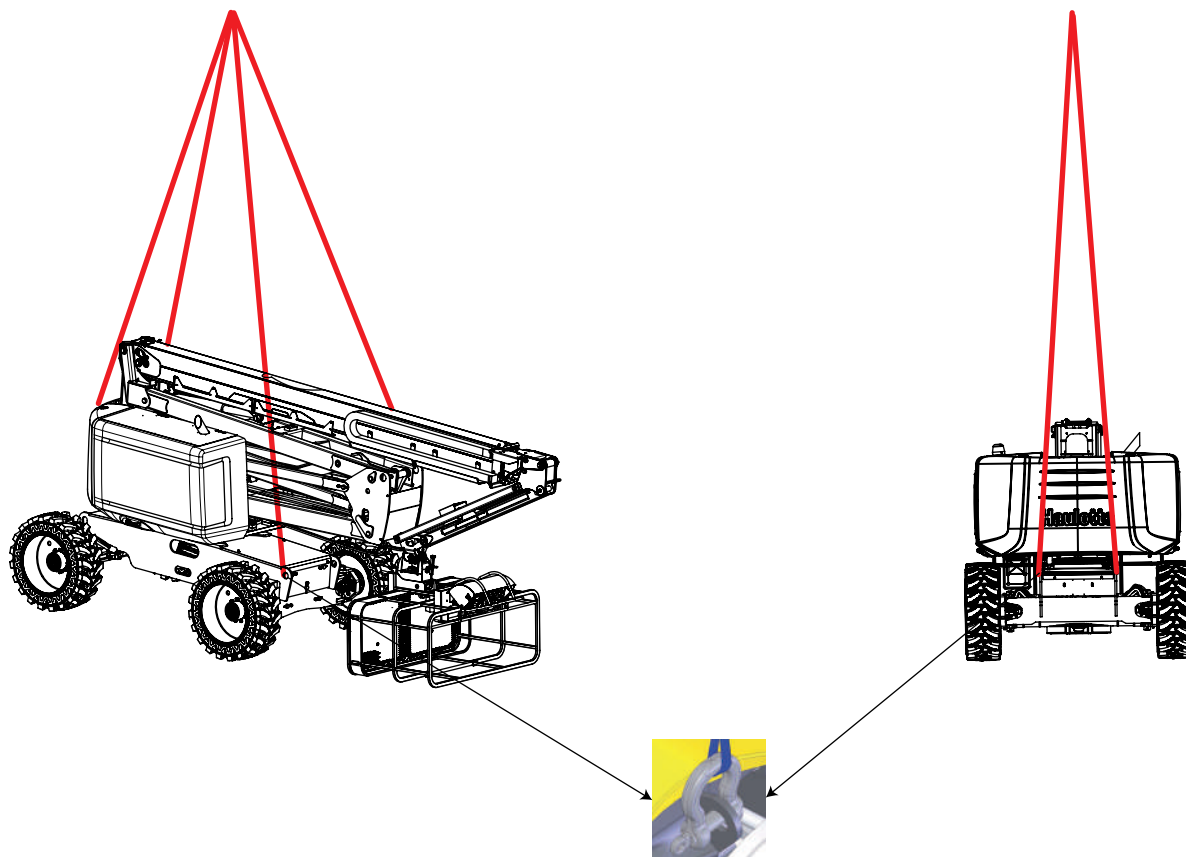

	Number of shackles	Number of slings	Length	Maximum load per sling and shackle
A	4	4	5 m (16 ft 5 in)	3000 daN (6744 lbf)

D - Operation instructions

6 - Cold Weather Recommendations

In cold weather conditions, allow engine to run for at least 5 min to warm up ; before operating any function thereby preventing any damage to the hydraulic system.

In extreme cold conditions, machines should be equipped with optional cold start kits.

Attempting to start engine when temperature is in the negative range, may require the use of a booster battery.

If engine fails to start, do not crank for an extended time. Allow starter to "cool off" for a few minutes before attempting again. If engine fails after several attempts, refer to the engine maintenance manual.

N.B.-:INITIAL STARTING SHOULD ALWAYS BE PERFORMED FROM THE GROUND CONTROL BOX.

N.B.-:WHEN POWER IS SWITCHED ON, THE LED (102) AT PLATFORM CONTROL DISPLAY PANEL FLASHES, INDICATING THAT THE ENGINE IS IN AUTOMATIC PRE-HEATING MODE. UPON THE EXTINCTION OF THIS LIGHT (JUST IN SECONDS) AT PLATFORM, STARTING OF THE MACHINE IS POSSIBLE.

6.1 - ENGINE OIL

The correct SAE viscosity grade of oil is determined by the minimum ambient temperature during cold engine start-up, and the maximum ambient temperature during engine operation.

Generally, use the highest viscosity oil that is available to meet the requirement for the temperature at start-up.

Viscosity index	Engine oil viscosity	
	Minimum	Maximum
SAE 0W20	-40°C (-40°F)	10°C (50°F)
SAE 0W30	-40°C (-40°F)	30°C (86°F)
SAE 0W40	-40°C (-40°F)	40°C (104°F)
SAE 5W30	-30°C (-22°F)	30°C (86°F)
SAE 5W40	-30°C (-22°F)	40°C (104°F)
SAE 10W30	-20°C (-4°F)	40°C (104°F)
SAE 15W40	-10°C (14°F)	50°C (122°F)

Classification API

Fuel type	Engine oil classification
High sulfur fuel ≤ [0.05% (500 ppm)] Sulfur content < 0.50% (5000 ppm)	API CJ-4 or CK-4 (If the engine oil is used with a high sulfur level, change the engine oil at shorter intervals, approximately half)

N.B.-:FOR ADDITIONAL ENGINE OIL RECOMMENDATIONS, REFER TO THE ENGINE MANUAL PROVIDED WITH THE MACHINE.

D - Operation instructions

6.2 - HYDRAULIC OIL

External environmental conditions can reduce performance of the machine if the hydraulic oil temperature does not reach its optimum range.

It is recommended to use the hydraulic oil according to weather condition. Refer to the table below.

Environmental conditions	SAE Viscosity grade
Ambient temperature between - 15°C (5°F) and + 40°C (+ 104°F)	HV 46
Ambient temperature between - 35°C (- 31°F) and + 35°C (+ 95°F)	HV 32
Ambient temperature between 0°C (+ 32°F) and + 45°C (+ 113°F)	HV 68

N.B.-:IT IS RECOMMENDED TO REPLACE LOW TEMPERATURE OIL AS THE AMBIENT TEMPERATURE REACHES + 15°C (59°F). IT IS NOT ADVISABLE TO MIX OILS OF DIFFERENT BRANDS OR TYPES.

E - General Specifications

1 - Machine dimensions

Stowed / Transport position : Configuration that takes the minimum floor space necessary for storage and / or delivery of the machine - Access position.

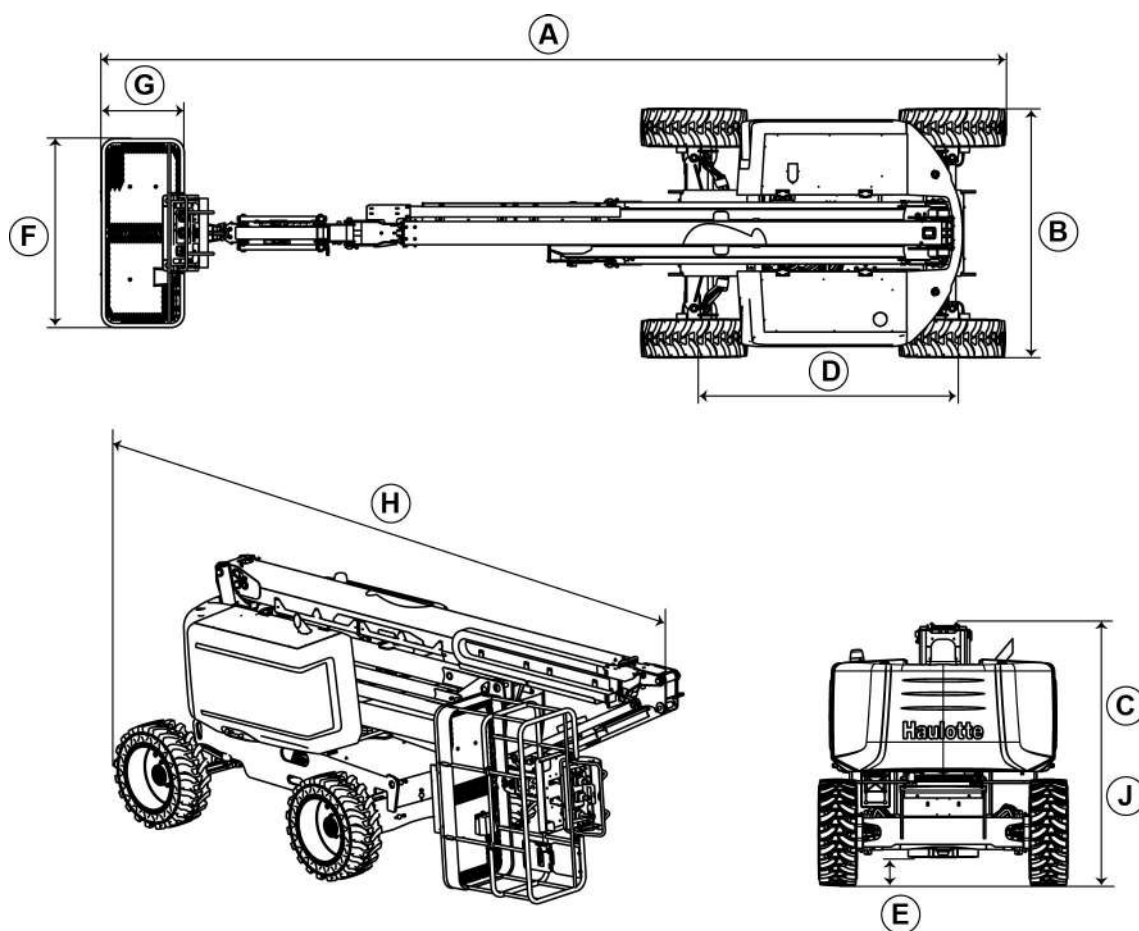

E - General Specifications

Machine		HA20RTJ		HA20RTJ O - HA61RTJ O	
Marking	Specifications - Dimensions	SI	Imp.	SI	Imp.
A	Overall length of machine	8,80 m	28 ft 10 in	8,80 m	28 ft 10 in
B	Overall width of machine	2,44 m	8 ft	2,44 m	8 ft
B	Overall width of machine - With sand tires	2,5 m	8 ft 2 in	2,5 m	8 ft 2 in
C	Overall height of machine	2,47 m	8 ft 1 in	2,47 m	8 ft 1 in
D	Wheel base	2,50 m	8 ft 2 in	2,50 m	8 ft 2 in
E	Ground clearance	38 cm	15 in	38 cm	15 in
F X G	Platform dimensions - Standard	1,8 x 0,8 m	5 ft 11 in x 2 ft 7 in	1,8 x 0,8 m	5 ft 11 in x 2 ft 7 in
F X G	Platform dimensions - Option	2,44 x 0,915 m	8 ft x 3 ft	2,44 x 0,915 m	8 ft x 3 ft
H	Storage length	6,50 m	21 ft 4 in	6,50 m	21 ft 4 in
J	Storage height	2,93 m	9 ft 7 in	2,93 m	9 ft 7 in

Machine		HA20RTJ PRO - HA61RTJ PRO	
Marking	Specifications - Dimensions	SI	Imp.
A	Overall length of machine	8,80 m	28 ft 10 in
B	Overall width of machine	2,44 m	8 ft 0 in
B	Overall width of machine - With sand tires	2,5 m	8 ft 2 in
C	Overall height of machine	2,51 m	8 ft 3 in
D	Wheel base	2,50 m	8 ft 2 in
E	Ground clearance	42 cm	15 in
F X G	Platform dimensions - Standard	1,8 x 0,8 m	5 ft 11 in x 2 ft 7 in
F X G	Platform dimensions - Option	2,44 x 0,915 m	8 ft x 3 ft
H	Storage length	6,50 m	21 ft 4 in
J	Storage height	2,93 m	9 ft 7 in

E - General Specifications

2 - Major component masses

N.B.-:MASSES MEASURED WITH EMPTY TANKS.

Component	HA20RTJ	HA20RTJ O - HA61RTJ O	HA20RTJ PRO - HA61RTJ PRO
Frame assembly mass	2 860 kg - 6,306 lbs	2 860 kg - 6,306 lbs	2 960 kg - 6,525 lbs
• Mass of each wheel 850 x 340	187kg +/- 4 kg (412 lb +/- 9 lb)		NA
• Mass of each wheel 1025 x 365	NA		290 kg +/- 6 kg (639 lb +/- 13 lb)
Turret assembly mass	900 kg - 1985 lbs		
• Counterweight mass - Turntable	2 560 kg - 5,645 lbs	2 760 kg - 6,086 lbs	2 560 kg - 5,645 lbs
• Engine compartment mass	400 kg - 882 lbs		
• Battery mass	20 kg - 44 lbs		
Boom assembly mass	750 kg - 1654 lbs		
Arm assembly mass	1 650 kg - 3,638 lbs		
Jib assembly mass	150 kg - 331 lbs		
Platform assembly mass	200 kg - 441 lbs		
Machine mass	9 300 kg - 20,502 lbs	9 500 kg - 20,944 lbs	9 600 kg - 21,168 lbs
Machine mass - With sand tires			9 800 kg - 21,605 lbs

E - General Specifications

3 - Acoustics and vibrations

The acoustics and vibrations specifications are based upon the following conditions :

- The airborne noise emissions at workstation are determined per European Directive 2006/42/CE.
- The guaranteed sound power level LWA (displayed on the product) is determined per European Directive 2000/14/CE.
- The vibrations transmitted by the machinery to the hand/arm system and to the whole body are determined per European Directive 2006/42/CE.

Specifications	
Sound pressure level at workstation	80 dBA
Guaranteed sound power level	104 dBA
Vibrations hand/arm	Vibration transmitted by this MEWP to the hand-arm does not exceed 2,5 m/s ² (98,4 in/s ²)
Vibrations whole body	Vibration transmitted by this MEWP to the whole body does not exceed 0,5 m/s ² (19,6 in/s ²)

4 - Wheel/Tire assembly

4.1 - TECHNICAL SPECIFICATIONS

Component	Standard wheel HA20RTJ	Standard wheel HA20RTJ O	Standard wheel HA20RTJ PRO
Reference number	4000278720		4000270770
	4000278730		4001037700
Type	Solid Tire (Curred - on)		
Wheel mass	187 kg +/- 4 kg (412 lbs +/- 9 lbs)		290 kg +/- 6 kg (639 lbs +/- 13 lbs)
Size	Solideal 850 x 340		Solideal 1025 x 365
Torque	320 Nm (236 ft lbs)		

E - General Specifications

4.2 - INSPECTION AND MAINTENANCE



The tire and rim are bonded together, both must be replaced if either is damaged.

Wheels replacement must be made in the following cases :

- Deformation or cracks on the rim.
- De-bonding between the interface of the steel and the rubber.
- Uniform wear to the wearing line :
 - 850 x 340 wheel : \varnothing 789 mm / 32 in
 - 1025 x 365 wheel : \varnothing 962 / 38 in



- Non-linear wearing of the tread profile (> 10%)

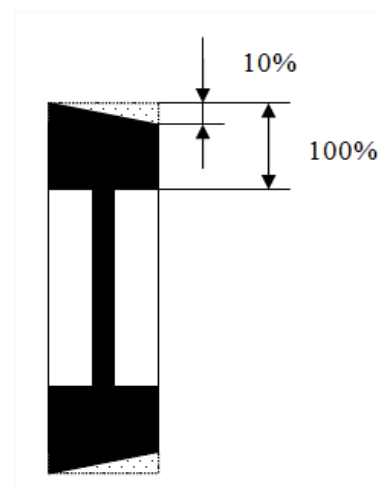

- Linear wear of the tread profile (> 25 %)

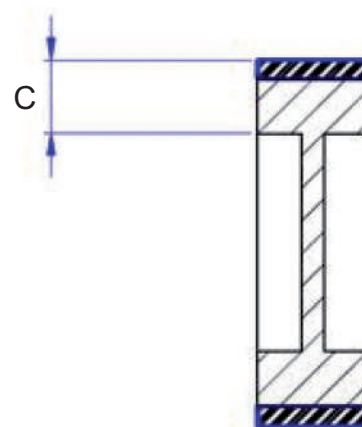

E - General Specifications

	Standard wheel HA20RTJ	Standard wheel HA20RTJ O	Standard wheel HA20RTJ PRO
New tire	C = 185 mm / 8 in		C = 168 mm / 7 in
Defective tire (Linear wear of the tread profile > 25 %)	C = 140 mm / 6 in		C = 126 mm / 5 in

- 1 wheel stud is completely torn.
- 2 successive wheel studs are partially torn.
- 2 aperture holes are cut.



Tires and rims are critical components for the stability of the machine. For safety reasons :

- Use only HAULOTTE® spare parts according to the technical characteristics of the machine. Refer to the spare parts catalog.
- Do not replace factory-installed tires with tires of different specifications or ply rating.
- Never replace a solid (rigid) tire with a foam-filled or a pneumatic (air-filled) tire.

Procedure of replacement :

- Loosen the wheel nuts on the wheel to be removed.
- Raise the machine using a jack or a hoist.
- Remove the wheel nuts.
- Remove the wheel.
- Install the new wheel.
- Lower the machine to the ground.
- Tighten the wheel nuts to the recommended torque. Refer to maintenance and repair manuals.

N.B.-:-IF A WHEEL HAS BEEN REPLACED, OBSERVING THE AXLE TRACK PATTERN CHECK FOR CORRECT INSTALLATION.

E - General Specifications

5 - Options

5.1 - ON-BOARD GENERATOR

5.1.1 - Description

The optional socket on the platform is supplied by a hydraulically powered generator. The generator is located in the engine compartment. The generator is activated by a switch on the platform control box. The power output and voltage available at the socket depends on the option installed.

5.1.2 - Characteristics

Nominal power output	Main output voltage	Alternating current frequency	Socket plug type	Regulation zone
3,5 kw	230 V	50 Hz	Single-phase	European community market
3,7 kw	115 V	50 Hz	Single-phase	United Kingdom market
3,7 kw	110 V	60 Hz	Single-phase	American market
6,5 kw	400 V	50 Hz	Three-phase	European conformity and Australian markets
9 kw	210 V	60 Hz	Three-phase	American market
9 kw	120 V	60 Hz	Single-phase	American market

5.1.3 - Safety precautions



- Please read the instructions before using the option.
- Make sure that no one is beneath the platform.
- Check that the voltage required by the tool matches the voltage supplied by the socket.
- Do not overload the power circuit.
- Do not use electrical tools in water.
- Do not exceed the maximum rated capacity.



Do not expose the platform socket to direct contact with a water beam or a pressure washer.

5.1.4 - Pre-operation inspection



- Check that the generator is securely attached, that there are no missing or loose parts and no damage.
- Check the hoses before use to make sure there are no leaks or damage.
- Check condition of belts and wiring.

E - General Specifications

5.1.5 - Operation

Power on :

- Start the machine.
- Heat the engine for 15 min before any operation.
- From the platform control box, move the generator selector switch (79) to the right to activate the generator. ( Section B - Platform control box)
- Connect the tool to the socket.
- Connect or disconnect from the socket at any time.

N.B.-:MACHINE MOVEMENTS ARE PREVENTED WHEN THE GENERATOR SWITCH IS ON.

Power off :

- Disconnect the tool from the socket.
- Move the generator selector switch (79) to the left to switch off the generator. ( Section B - Platform control box).
- Machine movements are once again functional.

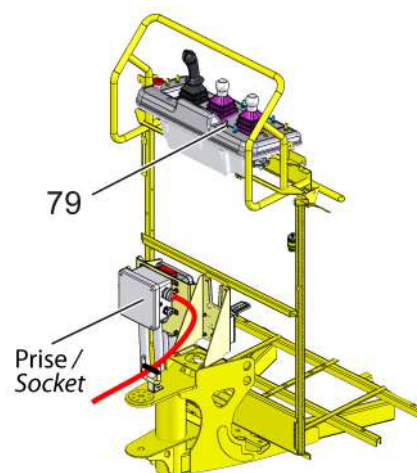

A

B

C

D

➤ E

F

G

H

I

E - General Specifications

5.2 - GLAZIER'S KIT

5.2.1 - Description

This attachment is an assembly designed to transport panels. The assembly comprises of a tray that extends along the length of the floor. The panel(s) should be placed in the tray and secured to the guard rail with a strap (not supplied).

N.B.-:-THIS TRAY CAN BE USED ONLY WITH A SIDE ENTRY PLATFORM.

5.2.2 - Characteristics

Component	Characteristics
Maximum capacity	115 kg (220 lbs)
Weight of attachment	10 kg (22 lbs)
Maximum load surface	3 m ² (32 sq.ft)
Maximum allowable height of the panel	1,20 m (3 ft 11 in)
Maximum allowed wind	CE / UKCA / AS : 12,5 ms - 45 km/h - 28 mph ANSI / CSA: 7 ms - 25 km/h - 15 mph

5.2.3 - Safety precautions



- Please read and assimilate the instructions before using the attachment.
- This attachment is designed for transporting panels. Do not use this attachment for transporting other types of load.
- Do not suspend loads.
- Do not overload the attachment and ensure that the equipment is correctly attached by means of a strap (not supplied).
- Do not exceed the maximum allowable platform capacity. The combined weight of the attachment, the panel(s) , the occupants, the tools and any other equipment must not exceed the maximum allowable platform capacity.
- Do not load panels whose surface area exceeds the maximum authorized surface area. Exposing an additional surface area to the wind reduces machine stability. Do not install any other attachments that increase the surface area exposed to the wind.
- Check that the position of the panel is not reducing visibility during maneuvers in the work environment. Do not transport panels whose height exceeds the authorized limit.
- When maneuvering, ensure that a safe distance is maintained between the panel and the obstacles in the work environment.
- Do not use the machine if the wind speed exceeds the allowable limit with the attachment.

5.2.4 - Pre-operation inspection



- Check that the tray has no cracks or other damage.
- Check that the cradle is correctly installed and secured to the platform.
- Check that the information decal is present on the cradle and is legible.
- Check that the strap is not twisted or torn.

E - General Specifications

5.2.5 - Operation

- Load the panel onto the tray on platform.
- Secure the panel tray on the guardrail by means of a strap (not supplied) with the correct strength and dimensions.

Strapping example(s) - Large panel



Strapping example(s) - Small panel



E - General Specifications

5.2.6 - Assembly / Dis-assembly

Tray



Marking	Description
1	Tray (Panel carrier)
2	Platform
3	Screws and nuts
4	Collars COLSON
5	Plastic protection

- Fix the tray (1) to the platform (2) using screws and bolts (3)
- Install plastic protection (5) on the handrail and attach it using collars (4)

N.B.-:-TORQUE REQUIREMENTS : 22 NM (15 FT LBS)

- Pre-operation test : Place a load of 176 kg (390 lbs) on the carrier and carry out an inspection. Refer to the chapter on pre-operation inspection.

E - General Specifications

5.2.7 - Specific decals

Location of the decals

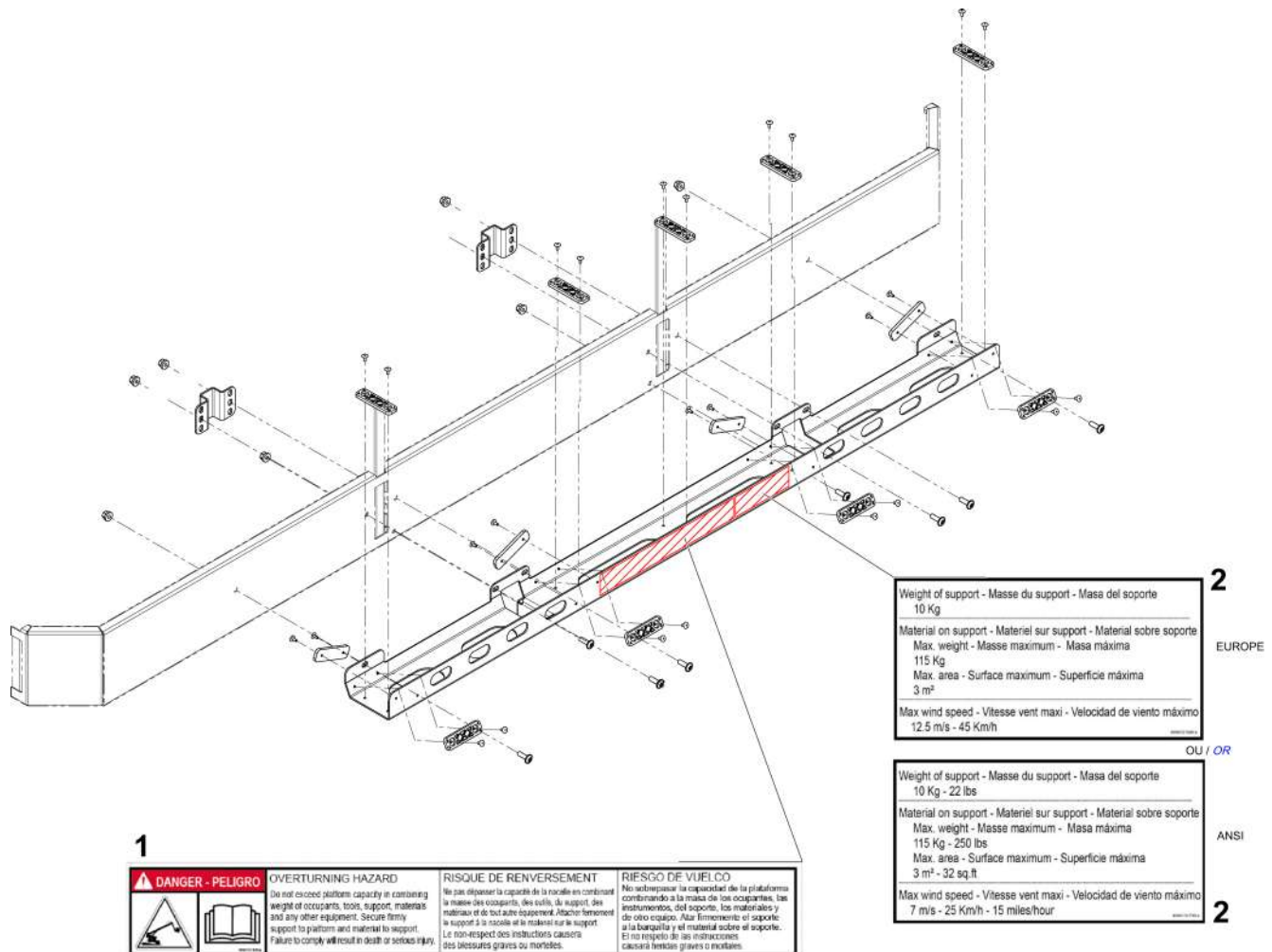

Marking	Description	Quantity	Part number
1	Risk of overturning	1	40000131830
2	Equipment characteristics	1	CE / UKCA / AS : 4000131630 ANSI / CSA: 4000131730

E - General Specifications

5.3 - PLUMBER'S KIT

5.3.1 - Description

This attachment is an assembly designed to transport pipes and tubes. The assembly comprises of 2 cradles securely attached to the platform. The load (material) should be placed in both the cradles and secured with a strap (not supplied).

5.3.2 - Characteristics

Component	Characteristics
Weight of the carrier	8 kg (20 lbs)
Weight of the equipment on the carrier	80 kg (175 lbs)
Maximum load surface	0,8 m ² (Ø 0,32 m x 2,5 m) / 8.6 sq.ft (Ø 1 ft x 8.6 ft)
Maximum wind speed allowed	12,5 m/s - 45 km/h - 28 mph

5.3.3 - Safety precautions



- Please read and assimilate the instructions before using the attachment.
- This attachment is designed for transporting pipes and tubes. Do not use this attachment for transporting other types of load. .
- Do not suspend loads.
- Do not overload the attachment and ensure that the equipment is correctly attached by means of a strap (not supplied).
- Do not exceed the maximum allowable platform capacity. The combined weight of the attachment, load, the occupants, the tools and any other equipment must not exceed the maximum allowable platform capacity.
- Do not load tubes whose surface area exceeds the maximum authorized surface area. Exposing an additional surface area to the wind reduces machine stability. Do not install any other attachments that increase the surface area exposed to the wind.
- Do not use the machine if the wind speed exceeds the authorized limit of the attachment.
- The cradles should always be positioned such that they are within the platform. Position the bottom end of the cradles such that they are resting on the platform floor.
- When maneuvering, ensure you maintain a safe distance between the load and the obstacles in the work environment.

5.3.4 - Pre-operation inspection



- Check that the cradle has no cracks or other damage.
- Check that the cradle is correctly installed and secured to the platform.
- Check that the information decal is present on the cradle and is legible.
- Check that the strap is not twisted or torn.
- Check that the position of the load and attachment is not obstructing access to the platform or the controls.
- Check that the position of the attachment and the load is not reducing visibility during maneuvers in the work environment.

E - General Specifications

5.3.5 - Operation

- Position the load to rest on the 2 cradles.
- Center the load on the cradles.
- Securely attach the load to each cradle with strap of adequate strength and dimensions.

Strapping example(s)



A

B

C

D

E

F

G

H

I

E - General Specifications

5.3.6 - Assembly - Dis-assembly

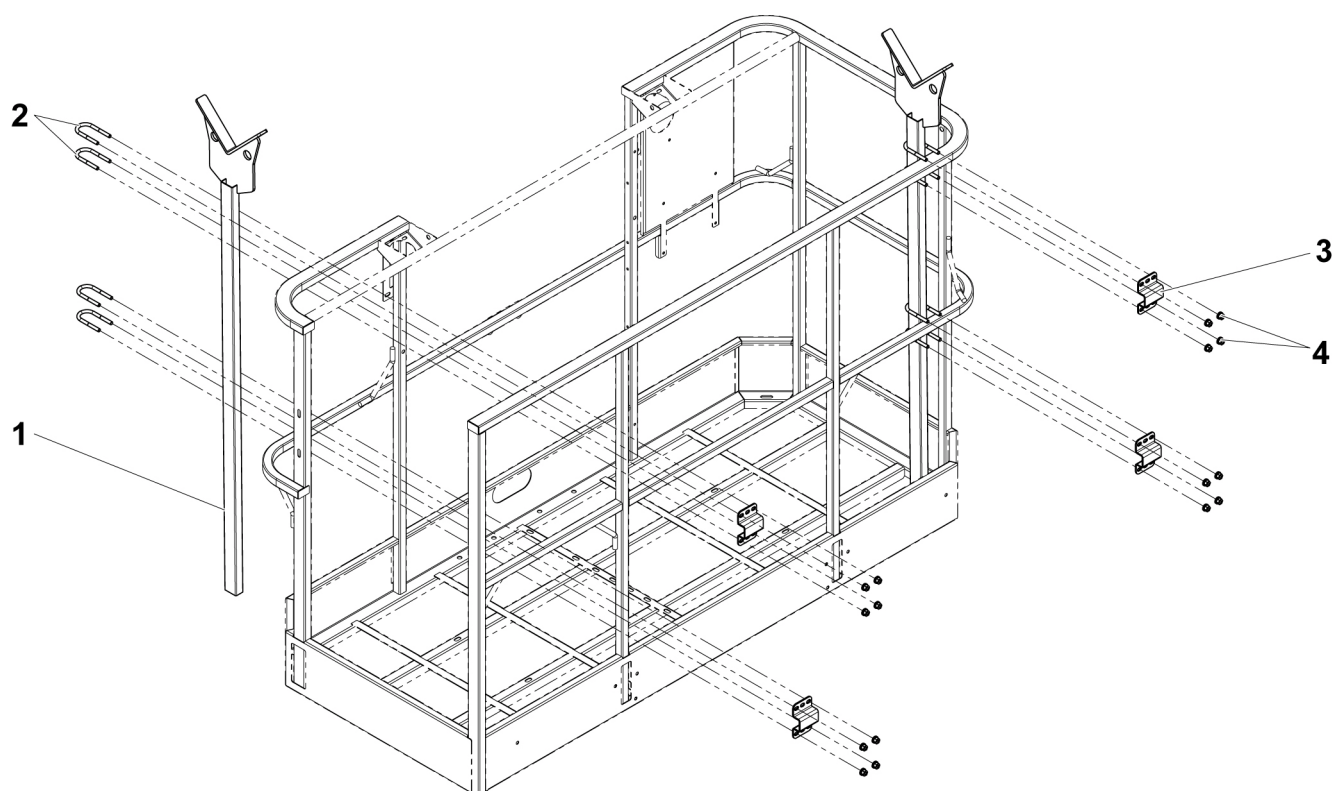

Marking	Description
1	Cradle
2	Fastening screw U bolt
3	Flange
4	Nuts

- Locate the cradles such that the load will be parallel to the length of the platform.
- Install two cradles (1) to the guardrails using 4 supplied flanges (3).
- Tighten up the flange using 2 supplied screw U bolts (2) and 4 nuts (4), wherever a cradle and the horizontal guardrail tubes intersect.

N.B.-:-TORQUE REQUIREMENTS : 22 NM (15 FT LBS)

- Ensure that the bottom of cradle is resting on the platform floor.
- Ensure that the distance between the 2 cradles support and center the load.
- Pre-operation test : Place and secure the load of 120 kg (265 lbs) on the cradles. Ensure that the cradles can support the load and that there is no visual structural damage.

E - General Specifications

5.3.7 - Specific decals, optional

Location of the decals

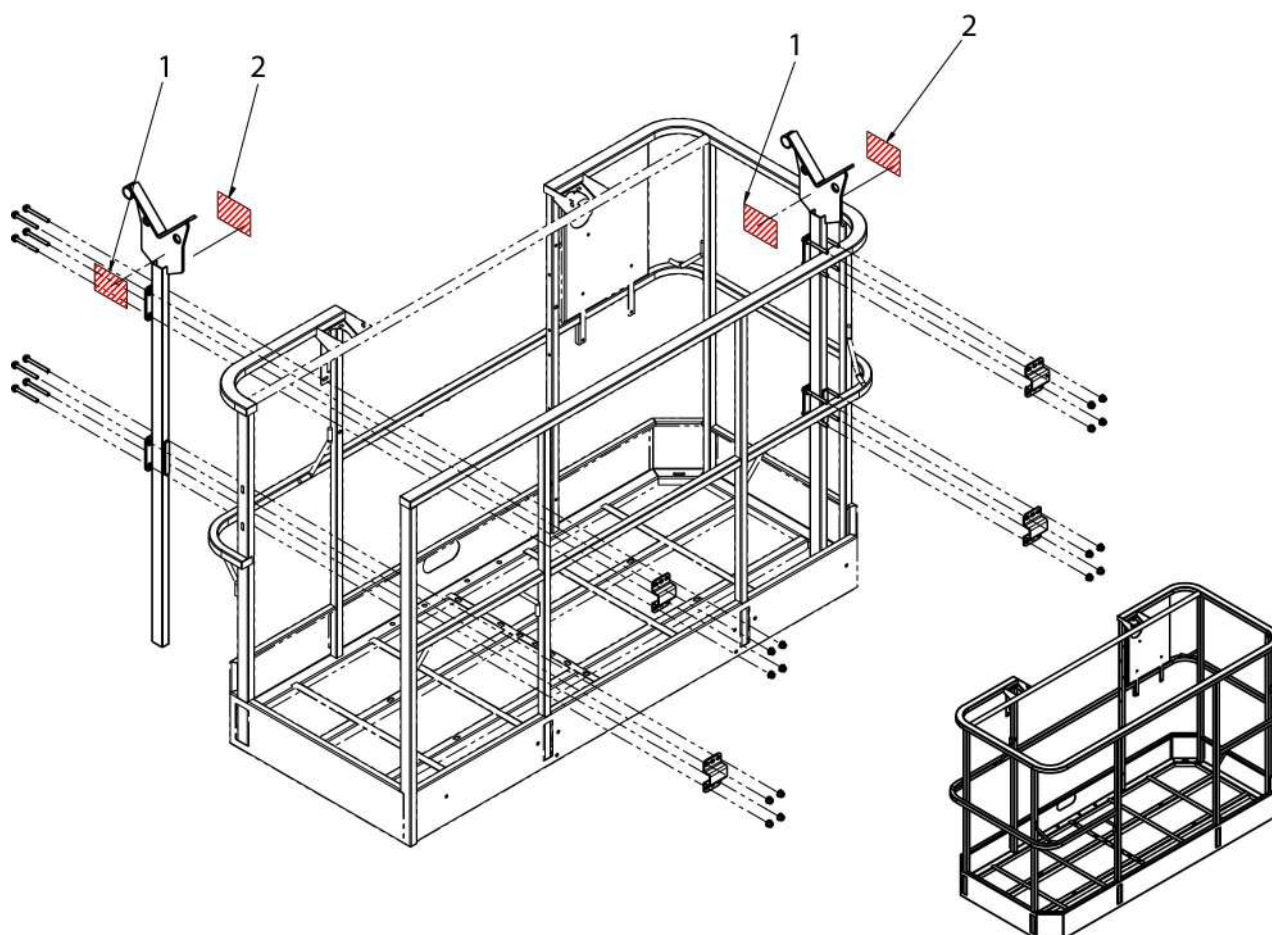

Marking	Description	Quantity	Part number
1	Risk of overturning	2	In english 4000131600 In french 4000131610 In spanish 4000131620 In german 4000708570
2	Equipment characteristics	2	4000131650

E - General Specifications

5.4 - ACTIV' SHIELD BAR - SECONDARY GUARDING SYSTEM (IF FITTED)

5.4.1 - Description



General Specification Activ' Shield Bar :

- The Activ' Shield Bar is a device designed to reduce the risk of entrapment against the control panel when the platform is in confined spaces.
- This device is complementary to the existing operator protection including the enable switch system (Trigger of joystick, Foot Switch and Enable Switch on ground control box).
- The Activ' Shield Bar is active when the platform is elevated (boom or arm) and creep speed is automatically engaged. It is not enabled when stationary or in the transport position, when drive, turret rotation and jib raise are possible.
- The green indicator light of the Activ' Shield Bar is illuminated indicating the device is active :
- Light flashing : Machine stationary in Activ' Shield Bar zone (The platform is elevated and the Activ' Shield Bar will be active during movements).
- Light on : Activ' Shield Bar is active.



This system does not relieve the operator from the responsibilities of learning and practicing the principles of safe use and operation of the machine as provided by the manufacturer's instructions, employer's safety rules and worksite regulations

5.4.2 - Characteristics

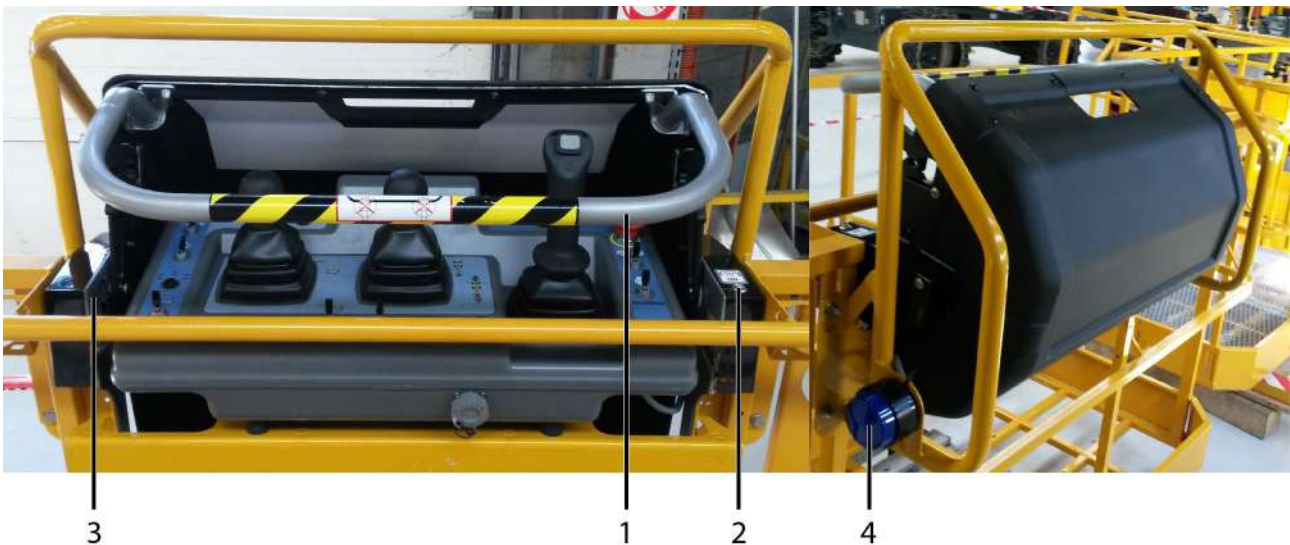

Marking	Description
1	Activation bar
2	Green indicator light
3	Sensor
4	Blue flashing light

E - General Specifications

5.4.3 - Safety precautions



It is mandatory to ensure that the **Activ' Shield Bar** is functional at each start-up of the machine



Do not use the **Activ' Shield Bar** as a handhold. This could result in an inadvertent triggering of the **Activ' Shield Bar**.

- Check the work area for overhead clearances, obstructions or other possible hazards.



- When driving, position the platform so as to provide the best visibility possible and avoid any blind spots.

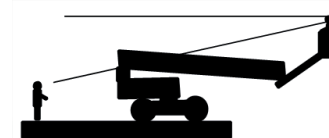

- Always ensure that the chassis is never driven any closer than 1 m (3 ft3 in) from holes, bumps, tilts, obstructions, debris and ground coverings that may hide dangers.
- During operation, keep all the parts of the body inside the platform.
- To position the machine close to obstacles, it is recommended to use boom movements (arm, boom, etc.) instead of the drive movements.
- Do not drive fast in narrow or cluttered areas. Keep speed under control while making turns or sharp bends.

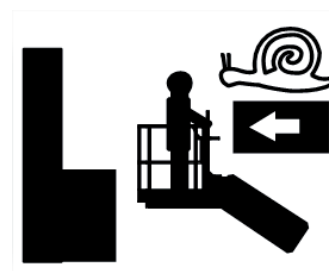

A

B

C

D

E

F

G

H

I

E - General Specifications

5.4.4 - Pre-operation inspection



- If any item on the checklist is marked NO during the inspection; machine must be tagged and locked out and placed out of service.
- DO NOT operate the machine until all identified items are corrected and it has been declared safe for operation.

Description	Yes	No
Perform all specified machine functional tests		
• All machine functional tests result positive		
Start the machine from platform control box		
Switch off (push in) all the emergency stop buttons		
• Check absence of warning signal		
• Check that the blue indicator (4) is not activated when the machine is in stowed position		
To ensure Activ' Shield Bar device is functioning correctly, perform the following :		
When stowed :		
• Check that the green indicator light (2) is not illuminated		
When boom or arm is raised above 15° :		
• Check that the green indicator light (2) is blinking-With platform stationary.		
• Check that the green indicator light (2) is illuminated-With platform in motion.		
Simultaneously make a movement and push forward the activation bar to trigger the system :		
• Check that all movements stop.		
• Check that the horn and the blue flashing light (4) are activated.		

N.B.-:-PRESS THE FOOT SWITCH TO RESET THE SYSTEM

5.4.5 - Operation

If the Activ' Shield Bar is pushed forward, all movements are stopped. The horn sounds and the warning blue light flashes. Only movements to move away from the entrapment are authorised.

To re-set the Activ' Shield Bar, release the activation bar, the Foot Switch and controls. Then, re-press the Foot Switch.

Care must be taken during all operations to prevent collision and entrapment against structures.

E - General Specifications

5.4.6 - Specific decals

Location of the decals



Marking	Description	Quantity	Part number
1	Do not lean on the bar	1	4000206690
2	Activ' Shield Bar controls	1	4000596720
3	Activ' Shield Bar instructions	1	4000609540

Activ' Shield Bar instructions

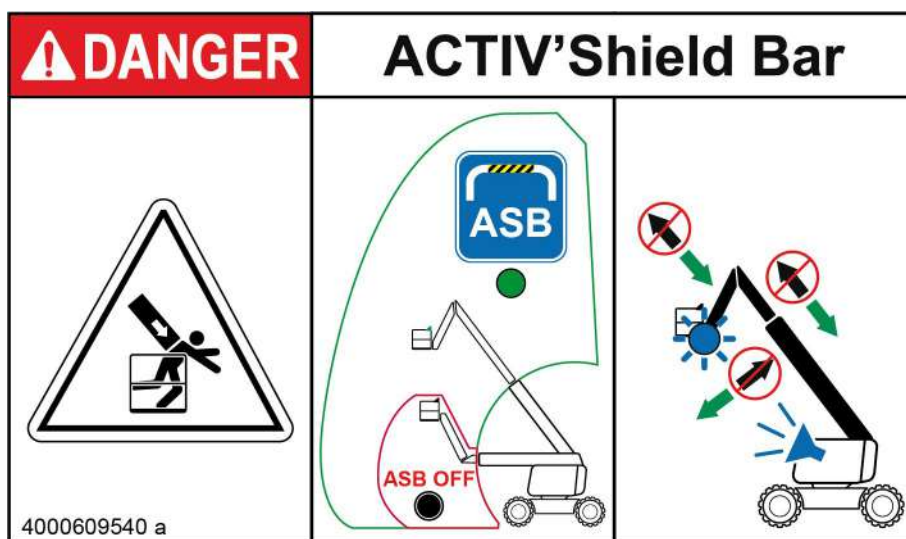

E - General Specifications

5.5 - SWING GATE

5.5.1 - Description

"SWING GATE" consists of a laterally mounted pivoting $\frac{1}{2}$ gate with closing latch, which enables a better access to platform. Spring loaded hinges and a latching mechanism allows the gate to swing inwards only.

Swing gate



5.5.2 - Characteristics

Width of the gate : 500 mm / 19.68 in

5.5.3 - Safety precautions



- The gate is part of the guardrail system and must be securely fastened after entering the platform.



- Pay attention to the toeboard when entering or leaving the platform.

5.5.4 - Pre-operation instructions

- Inspect that the latching mechanism is securely fastened.
- Check the hinges and latch operate correctly and are not deformed.
- Ensure that the gate returns automatically to the closed and fastened position after entering or exiting the platform.

F - Maintenance

1 - General

As an owner and/or operator of Haulotte equipment, your Safety is of utmost importance to HAULOTTE®, which is why HAULOTTE® places such a high priority on product safety.

INSPECTIONS are not only required by HAULOTTE®, but may also be required by industry standards and/or local regulations.

To ensure your equipment continues to achieve the level of performance set in the factory, it is important to maintain it regularly. We remind you that it is strictly forbidden to make any modifications. Regular and timely inspections will reduce equipment down time as well as prevent possible injury.

N.B.: -DO NOT OPERATE UNLESS YOU ARE FAMILIAR AND TRAINED IN THE PRINCIPLES OF SAFE MACHINE OPERATION.

Overview :

- Walk-around inspections take only a few minutes at the beginning and end of each shift – one of the best ways to prevent mechanical problems and safety hazards.

What to Do :

- Use your senses: sight, smell, hearing and touch.

Frequency :

- Check your machine periodically during your entire workday.
- Make sure to do your inspection the same way every time.
- Complete one of these inspections at the start and end of each shift.

N.B.: -IF DAMAGE OR UNAUTHORIZED MODIFICATIONS ARE DISCOVERED, THE MACHINE MUST BE REMOVED FROM SERVICE UNTIL REPAIRS ARE MADE BY A QUALIFIED SERVICE TECHNICIAN.

It is the owner's responsibility to ensure the required maintenance as recommended by Haulotte is completed prior to the operation of the machine.

If regular maintenance is not carried out, this may :

- Void the warranty.
- Cause machine malfunction.
- Reduce machine reliability and shorten its service life.
- Jeopardize operator safety.

HAULOTTE Services® technicians are specially trained to carry out extensive repairs, interventions or adjustments on the safety systems or elements of HAULOTTE® machines. They carry genuine HAULOTTE spare parts and tools as required, and also provide fully documented reports on all work completed.

The inspection and maintenance table, identifies the role and the responsibilities of each party in periodical machine maintenance.  Section C 3 - Inspection and Functional test.

F - Maintenance

2 - Maintenance Schedule

This section provides the necessary information needed to place the machine in safe operation. In accordance with the regulations that are currently applicable, this machine is designed to have a 10 year life span in normal usage conditions. The life may be extended or reduced dependent on the severity of operating conditions, the machine condition itself and by conducting effective inspections and maintenance in addition to other external factors. There are a number of factors which can affect the design life including but not limited to, severity of operating conditions/routine maintenance which should be carried out in accordance with this manual.

Severity of operating conditions may require a reduction in time between maintenance periods. Machines that have been out of service or have not been in use for more than 3 months must undergo a periodic inspection before the machine is put back into service.

Maintenance must be carried out by a competent company or person familiar with mechanical procedures.

Maintenance operations performed must be recorded in a register / log book of the machine.

F - Maintenance

3 - Inspection program

3.1 - GENERAL PROGRAM

The machine must be inspected on a regular basis at intervals of no less than once 1 per year. The purpose of the inspection is to detect any defect which could lead to an accident during routine use of the machine. Local standards and regulations may require more frequent inspections.

HAULOTTE® requires Reinforced and Major Inspections to be carried out on the product to extend its service life.

Inspections must be carried out by a competent company or person.

The inspection results must be recorded in the safety register or machine log book controlled and overseen by the company manager. This register or machine log book and the list of competent repair persons must be made available to the government work inspector and HAULOTTE Services®.

When	Responsible	Stakeholder	What
Before sale	Owner (or renter)	Competent technician or qualified technician HAULOTTE Services®	Periodic inspection
Before rent	Owner (or renter)	Competent technician or qualified technician HAULOTTE Services®	Daily inspection
Before use or every change of user	User	User	Daily inspection
Annually (1 year)	Owner (or renter)	Competent technician or qualified technician HAULOTTE Services®	Periodic inspection
5 years	Owner (or renter)	Qualified technician HAULOTTE Services®	Reinforced inspection
10 years	Owner (or renter)	Qualified technician HAULOTTE Services®	Major inspection

F - Maintenance

3.2 - DAILY INSPECTION

The Daily inspection includes a visual inspection, operational checks and testing of the safety systems. This must be conducted by the operator before using the machine.

This inspection is the responsibility of the user. Refer to  Section C 3.1 - Daily inspection.

3.3 - PERIODIC INSPECTION

The Periodic inspection is a thorough evaluation of the operation and safety features of the machine.

It must be conducted before the sale / resale of the machine and/or at least once every year.

Local regulations may have specific requirements on frequency, and content of inspections.

The severity of operating conditions may require frequent inspections.

This inspection is the responsibility of the owner, and inspections must be carried out by a competent company or person.

This inspection is in addition to the daily inspection.

This inspection should also be conducted after :

- Extensive dismantling and reassembly of major components.
- Repairs involving the machine's essential components.
- Any accident causing stress to the machine.

3.4 - REINFORCED INSPECTION

The Reinforced inspection is a thorough evaluation of the machine's structural components, to ensure proper functionality of the machine.

This evaluation must occur at a frequency of 5000 hours or every 5 years.

This inspection is the responsibility of the owner, and it must be conducted by a HAULOTTE Services® technician or by a competent company or person.

This inspection includes :

- Daily inspection
- Periodic inspection

N.B.-:-REFER TO THE MAINTENANCE MANUAL FOR DETAILS.

F - Maintenance

3.5 - MAJOR INSPECTION

The Major inspection is a thorough evaluation of the machine's integrity and proper functioning; after a normal service life of 10 years.

This evaluation must take place after 10 years of operation and then repeated every 5 years thereafter.

The severity of operating conditions may require frequent inspections.

This inspection is the responsibility of the owner, and it must be conducted by a HAULOTTE Services® technician or by a competent company or person.

This inspection includes :

- Daily inspection
- Periodic inspection
- Reinforced inspection

N.B.-:-REFER TO THE MAINTENANCE MANUAL FOR DETAILS.

A

B

C

D

E

F

G

H

I

F - Maintenance

4 - Repairs and adjustments

Extensive repairs, interventions or adjustments on the safety systems or components must be performed by a HAULOTTE Services® technician. Use original spare parts and components only.

N.B.-:HAULOTTE SERVICES® TECHNICIANS ARE TRAINED PROFESSIONALS TO PERFORM EXTENSIVE REPAIRS, INTERVENTIONS AND ADJUSTMENTS ON THE SAFETY SYSTEMS OR COMPONENTS OF HAULOTTE® MACHINES. THE TECHNICIAN CARRIES GENUINE HAULOTTE® SPARE PARTS AND TOOLS AS REQUIRED, AND ALSO PROVIDES FULLY DOCUMENTED REPORTS ON ALL WORK COMPLETED.

HAULOTTE Services® will not take responsibility for any outcomes resulting from inferior services or repairs performed by other unauthorised personnel.

HAULOTTE® reminds that NO modifications SHALL be carried out without the written permission of HAULOTTE®.

Any unauthorised repairs/modifications will void HAULOTTE® warranty.

To check for safety campaigns, consult our website : www.haulotte.com



N.B.-:WHEN DISPOSING OR SCRAPPING THIS MACHINE, PLEASE CONSIDER APPROPRIATE METHODS OF RECYCLING. ANY ITEMS THAT REQUIRE SPECIFIC DISPOSAL ARE LISTED WITH INSTRUCTIONS IN THE MAINTENANCE MANUAL.

G. Other information

1 - Conditions of warranty

Our warranty conditions and extension contracts are now available on the websites of our sales network : www.haulotte.com







2 - Subsidiary contact information

	<p>HAULOTTE FRANCE PARC DES LUMIERES 601 RUE NICEPHORE NIEPCE 69800 SAINT-PIERRE TECHNICAL Department: +33 (0)820 200 089 SPARE PARTS : +33 (0)820 205 344 FAX : +33 (0)4 72 88 01 43 E-mail : haulottefrance@haulotte.com www.haulotte.fr</p>		<p>HAULOTTE ITALIA VIA LOMBARDIA 15 20098 SAN GIULIANO MILANESE (MI) TEL : +39 02 98 97 01 FAX: +39 02 9897 01 25 E-mail : haulotteitalia@haulotte.com www.haulotte.it</p>		<p>HAULOTTE INDIA Unit No. 1205, 12th floor, Bhumiraj Costarica, Plot No. 1&2, Sector 18, Palm Beach Road, Sanpada, Navi Mumbai- 400 705 Maharashtra, INDIA Tel. : +91 22 66739531 to 35 E-mail : hlindia@haulotte.com www.haulotte.in</p>
	<p>HAULOTTE HUBARBEITSBÜHNEN GmbH Ehrenkirchener Strasse 2 D-79427 ESCHBACH TEL : +49 (0) 7634 50 67 - 0 FAX : +49 (0) 7634 50 67 - 119 E-mail : adv-gmbh@haulotte.com www.haulotte.de</p>		<p>HAULOTTE VOSTOK 61A, bld.1, RYABINOVAYA STREET 121471 MOSCOW RUSSIA TEL/FAX : +7 495 221 53 02 / 03 E-mail : salesrus@haulotte.com www.haulottevostok.ru</p>		<p>HAULOTTE DO BRASIL Av. Alameda Caiapós, 589 CEP: 06460-110 – TAMBORÉ BARUERI – SAO PAULO – BRASIL TEL : +55 11 4196 4300 FAX : +55 11 4196 4316 E-mail : haulottebrasil@haulotte.com www.haulotte.com.br</p>
	<p>HAULOTTE IBERICA C/ARGENTINA Nº 13 - P.I. LA GARENA 28806 ALCALA DE HENARES MADRID TEL : +34 902 886 455 TEL SAT : +34 902 886 444 FAX : +34 911 341 844 E-mail : iberica@haulotte.com www.haulotte.es</p>		<p>HAULOTTE POLSKA Sp. Z.o.o. UL. GRANICZNA 22 05-090 RASZYN - JANKI TEL : +48 22 720 08 80 FAX : +48 22 720 35 06 E-mail : E-mail : haulottepolska@haulotte.com www.haulotte.pl</p>		<p>HAULOTTE MÉXICO, S.A. de C.V. Calle 40 SUR ESQUINA 13 ESTE No. 5/N Colonia CIVAC, JUITEPEC, MORELOS CP 62578 México TEL : +52 77 7321 7923 FAX : +52 77 7516 8234 E-mail : haulotte.mexico@haulotte.com www.haulotte.com.mx</p>
	<p>HAULOTTE in JAPAN SBJ ShinOsaka BLDG 3F 4-6-5 Nishinakajima Yodogawa-ku, Osaka, JAPAN, Post Code: 532-0011 TEL : +81 6 6795 9008 FAX : +81 6 6795 9009 www.haulotte.com</p>		<p>HAULOTTE SINGAPORE Pte Ltd. No.26 CHANGI NORTH WAY, SINGAPORE 498812 Parts and service Hotline: +65 6546 6150 FAX : +65 6536 3969 E-mail : haulotteasia@haulotte.com www.haulotte.sg</p>		<p>HAULOTTE MIDDLE EAST FZE PO BOX 293881 Dubai Airport Free Zone DUBAI United Arab Emirates TEL : +971 (0)4 299 77 35 FAX : +971 (0) 4 299 60 28 E-mail : haulottemiddle-east@haulotte.com www.haulotte.ae</p>
	<p>HAULOTTE SCANDINAVIA AB Taljegårdsgatan 12 431 53 Mölndal SWEDEN TEL : +46 31 744 32 90 FAX : +46 31 744 32 99 E-mail : info@se.haulotte.com spares@se.haulotte.com www.haulotte.se</p>		<p>HAULOTTE TRADING (SHANGHAI) Co. Ltd. #7 WORKSHOP No 191 HUA JIN ROAD MIN HANG DISTRICT SHANGHAI 201108 CHINA TEL : +86 21 6442 6610 FAX : +86 21 6442 6619 E-mail : haulotteshanghai@haulotte.com www.haulotte.cn</p>		<p>HAULOTTE ARGENTINA Ruta Panamericana Km. 34,300 (Ramal A Escobar) 1615 Gran Bourg (Provincia de Buenos Aires) Argentina TEL : +54 33 27 445991 FAX : +54 33 27 452191 E-mail : haulotteargentina@haulotte.com www.haulotte.com.ar</p>
	<p>HAULOTTE UK Ltd 1 Gravely Way Four Ashes Wolverhampton WV10 7GW ENGLAND TEL : +44 (0)1216 199753 FAX : +44 (0)1952 292758 E-mail : salesuk@haulotte.com www.haulotte.co.uk</p>		<p>HAULOTTE GROUP / BILJAX 125 TAYLOR PARKWAY ARCHBOLD, OH 43502 – USA TEL : +1 419 445 8915 FAX : +1 419 445 0367 Toll free : +1 800 537 0540 E-mail : sales@us.haulotte.com www.haulotte-usa.com</p>		<p>HAULOTTE NORTH AMERICA 3409 Chandler Creek Rd. VIRGINIA BEACH, VA 23453 – USA TEL : +1 757 689 2146 FAX : +1 757 689 2175 Toll free : +1 800 537 0540 E-mail : sales@us.haulotte.com www.haulotte-usa.com</p>
	<p>HAULOTTE NETHERLANDS BV Koopvaardijweg 26 4906 CV OOSTERHOUT - Nederland TEL : +31 (0) 162 670 707 FAX : +31 (0) 162 670 710 E-mail info@haulotte.nl www.haulotte.nl</p>		<p>HAULOTTE AUSTRALIA PTY Ltd 51 Port Link Drive DANDENONG – VIC – 3175 TEN : 1 300 207 683 FAX : +61 (0)3 9792 1011 E-mail : sales@haulotte.com.au www.haulotte.com.au</p>		<p>HAULOTTE CHILE Panamerica Norte Altura Km 21,5 Colina (Cruce C/Lo Pinto) Santiago (RM) TEL : +562 2 3727630 E-mail : haulotte-chile@haulotte.com www.haulotte-chile.com</p>

G. Other information

2.1 - CALIFORNIA WARNING

For the US destined machines (ANSI and CSA standards)

<p>CALIFORNIA</p>  <p>Proposition 65 Warning</p> <p>Operating, servicing and maintaining a passenger vehicle or off-road vehicle can expose you to chemicals including engine exhaust, carbon monoxide, phthalates, and lead, which are known to the State of California to cause cancer and birth defects or other reproductive harm. To minimize exposure, avoid breathing exhaust, do not idle the engine except as necessary, service your vehicle in a well-ventilated area and wear gloves or wash your hands frequently when servicing your vehicle.</p> <p>For more information go to  www.P65Warnings.ca.gov/passenger-vehicle</p>
<p>CALIFORNIE</p>  <p>Avertissement de la Proposition 65</p> <p>L'exploitation, l'entretien et la maintenance d'un véhicule de tourisme ou d'un véhicule tout-terrain peuvent vous exposer à des produits chimiques, y compris les gaz d'échappement, le monoxyde de carbone, les phthalates et le plomb, identifiés par l'État de Californie comme pouvant causer le cancer et des malformations congénitales ou autres effets nocifs sur la reproduction. Pour limiter toute exposition: évitez de respirer les gaz d'échappement, ne laissez pas tourner le moteur au ralenti sauf si nécessaire, faites l'entretien du véhicule dans une zone bien aérée et portez des gants ou lavez vous fréquemment les mains lors de cette opération.</p> <p>Pour de plus amples informations, consulter  www.P65Warnings.ca.gov/passenger-vehicle</p>
<p>CALIFORNIA</p>  <p>Advertencia de la Proposición 65</p> <p>Operar, dar servicio y mantenimiento a un vehículo de pasajeros o vehículo todo terreno puede exponerle a químicos incluyendo gases del escape, monóxido de carbono, ftalatos y plomo, los cuales son conocidos por el Estado de California como causantes de cáncer y defectos de nacimiento u otros daños reproductivos. Para minimizar la exposición, evite respirar los gases del escape, no encienda el motor excepto si es necesario, dé servicio a su vehículo en un área bien ventilada y utilice guantes o lave sus manos frecuentemente cuando dé servicio a su vehículo.</p> <p>Para mayor información visite  www.P65Warnings.ca.gov/passenger-vehicle</p>

G. Other information

For the engine powered machines destined to the US market (Standards ANSI and CSA)

CALIFORNIA



Proposition 65 Warning

Breathing diesel engine exhaust exposes you to chemicals known to the State of California to cause cancer and birth defects or other reproductive harm.

- ✓ Always start and operate the engine in a well-ventilated area.
- ✓ If in an enclosed area, vent the exhaust to the outside.
- ✓ Do not modify or tamper with the exhaust system.
- ✓ Do not idle the engine except as necessary.

For more information go to  www.P65Warnings.ca.gov/diesel

CALIFORNIE



Avertissement de la Proposition 65

Respirer les gaz d'échappement de moteurs diesel peut vous exposer à des agents chimiques identifiés par l'État de Californie comme pouvant causer le cancer et des malformations congénitales ou autres effets nocifs sur la reproduction.

- ✓ Toujours démarrer et faire tourner le moteur dans une zone bien aérée.
- ✓ Si la zone est mal ventilée, évacuer les gaz d'échappement à l'extérieur.
- ✓ Ne pas modifier ou altérer le système d'échappement.
- ✓ Ne laisser le moteur tourner au ralenti que si cela est nécessaire.

Pour de plus amples informations, consulter  www.P65Warnings.ca.gov/diesel

CALIFORNIA



Advertencia de la Proposición 65

Respirar los gases del escape de motores a diésel le expone a químicos conocidos por el Estado de California como causantes de cáncer y defectos de nacimiento u otros daños reproductivos.

- ✓ Siempre encienda y opere el motor en un área bien ventilada.
- ✓ Si es en un área cerrada, ventile el orificio del escape hacia el exterior.
- ✓ Ne pas modifier ou altérer le système d'échappement.
- ✓ No modifique ni altere el sistema de escape.

Para mayor información visite  www.P65Warnings.ca.gov/diesel

H - Intervention register

1 - Intervention register

The intervention register keeps a record of maintenance and repair work carried out inside or outside the maintenance programme.

N.B.: - IN THE CASE OF A HAULOTTE SERVICES® INTERVENTION, THE QUALIFIED TECHNICIAN MUST INDICATE THE HAULOTTE SERVICES® INTERVENTION NUMBER.

Date	Type of intervention	Number of hours	Intervenor	HAULOTTE Services® intervention number

A

B

C

D

E

F

G

H

I

H - Intervention register

Date	Type of intervention	Number of hours	Intervenor	HAULOTTE Services® intervention number